

SERVICE MANUAL

STEREO RECEIVER

SX-939

KCU, F, GN

NOTE:

MODEL SX-939 COMES IN THREE VERSIONS DISTINGUISHED AS FOLLOWS:

Round label on rear panel	Voltage	Type
KCU F	120V only 110V, 120V, 130V 220V and 240V (switchable)	UL (U.S.A.) and CSA (Canada) approved.
GN	220V only	General export model SEMCO (Sweden), NEMCO (Norway) and DEMCO (Denmark) approved.



PIONEER®

CONTENTS

About 220V only model labeled "GN"

This model whose rear panel is labeled "GN" circular mark operates only on 220V, substantially in its circuit design from two other models. When repairing this model, please see the manual on page 71 and the followings which include such items as Circuit connection diagram, Miscellaneous parts list, Schematic diagram of power supply circuit assembly, P.C. board pattern and its parts list.

Before servicing, also please do not fail to check to see if the "GN" mark is labeled on the rear panel.

1.	SPECIFICATIONS	2
2.	FRONT PANEL FACILITIES	5
3.	CONNECTION DIAGRAM	7
4.	BLOCK DIAGRAM	9
5.	CIRCUIT DESCRIPTION	11
6.	LEVEL DIAGRAM	12
7.	DISASSEMBLY	13
8.	PARTS AND P.C. BOARD LOCATIONS	14
9.	DIAL CORD STRINGING	16
10.	ALIGNMENT PROCEDURE	
	10.1 English	17
	10.2 Germany (Abgleichverfahren)	79
11.	EXPLODED VIEW AND PARTS LIST	20
12.	SCHMATIC DIAGRAMS, P.C. BOARD PATTERNS AND PARTS LIST	
	12.1 Circuit Connection Diagram and Miscellaneous Parts	27
	12.2 Tuner Assembly (AWE-041)	32
	12.3 Muting Circuit Assembly (AWM-063)	38
	12.4 Equalizer Amplifier Assembly (AWF-013)	40
	12.5 Control Amplifier Assembly (AWG-027)	43
	12.6 Power Amplifier Assembly (AWH-030)	48
	12.7 Protection Circuit Assembly (AWM-062)	53
	12.8 Power Supply Circuit Assembly (AWR-052)	56
	12.9 Switch Circuit Assembly (AWS-064)	59
	12.10 Switch Circuit Assembly (AWS-065)	61
	12.11 Switch Circuit Assembly (AWS-066)	62
	12.12 Switch Circuit Assembly (AWS-067)	64
	12.13 Switch Circuit Assembly (AWS-068)	66
	12.14 Switch Circuit Assembly (AWS-069)	67
	12.15 5P Connector Assembly (AWX-062)	69
13.	PACKING METHOD AND PART NUMBERS	70
14.	SCHMATIC DIAGRAMS, P.C. BOARD PATTERN AND PARTS LIST FOR 220V ONLY MODEL	
	14.1 Circuit Connection Diagram and Miscellaneous Parts	71
	14.2 Power Supply Circuit Assembly (AWR-056)	76

1. SPECIFICATIONS

SEMICONDUCTORS

FETs	3
ICs	4
Transistors	57
Diodes	39

AMPLIFIER SECTION

Continuous Power Output

20Hz~20kHz

(Both channels driven) 70W + 70W (8Ω), 80W + 80W (4Ω)

1kHz (Both channels driven) 75W + 75W (8Ω), 100W + 100W (4Ω)

Harmonic Distortion

(20Hz~20kHz Continuous

Power Output) Less than 0.3%

(1W + 1W, Power Output) Less than 0.05%

Intermodulation Distortion

(Continuous Power Output) Less than 0.3%

(1W + 1W, Power Output)..... Less than 0.05%

Power Bandwidth

(IHF, Both channels driven) 5Hz~40kHz (T.H.D. 0.3%)

Frequency Response

7Hz~100kHz

Input Sensitivity/Impedance

POWER AMP IN 1V/50kΩ

Output

Speaker A, B, C, A + B, A + C, B + C (4Ω~16Ω)

Headphone 4Ω~16Ω

Damping Factor

(1kHz, 8Ω) More than 45

Hum & Noise

(IHF, short-circuited,

A Network) More than 110dB

Residual Hum & Noise

(8Ω, Pre & Power amplifier) Less than 1mV

PREAMPLIFIER SECTION

Input Sensitivity/Impedance

PHONO 1 2.5mV/50kΩ

PHONO 2 2.5mV/50kΩ

PHONO Overload Level

(rms/p-p) 250mV/700mV

MIC 2.0mV/50kΩ

AUX 150mV/70kΩ

TAPE PB 1, 2 150mV/70kΩ

TAPE PB 2 (DIN connector)..... 150mV/70kΩ

Output Level/Impedance

TAPE REC 1, 2 150mV

TAPE REC 2 (DIN connector) 30mV/80kΩ

PRE OUT 1V/1kΩ

Harmonic Distortion

(20Hz~20kHz) Less than 0.1%

Frequency Response

PHONO (RIAA equalization)	30Hz~15kHz±0.3dB
AUX, TAPE PB	10Hz~40kHz ⁺⁰ ₋₁ dB

Tone Control

BASS:	
MAIN	±10dB (100Hz)
SUB	±5dB (50Hz)
TREBLE:	
MAIN	±10dB (10kHz)
SUB	±5dB (20kHz)

Filter

LOW Cut	-8dB (50Hz) 6dB/oct.
HIGH Cut	-9dB (10kHz) 6dB/oct.

Loudness Contour

(Volume control set at -40dB position)	+8dB (100Hz), +4dB (10kHz)
---	----------------------------

Hum & Noise

(IHF, short-circuited, A Network)	
PHONO	More than 70dB
MIC	More than 65dB
AUX, TAPE PB	More than 95dB

Muting -20dB

FM SECTION

Usable Sensitivity (IHF)	1.8µV
Capture Ratio (IHF).....	1.0dB
Selectivity (IHF)	80dB
Signal-to-Noise Ratio	70dB
Image Rejection (98MHz)	85dB
IF Rejection (98MHz)	100dB
Spurious Rejection.....	100dB
AM Suppression	55dB

Harmonic Distortion:

MONO	Less than 0.2%
STEREO	Less than 0.4%

Frequency Response	20Hz~15kHz ^{+0.2} _{-2.0} dB
	50Hz~10kHz ^{+0.2} _{-0.5} dB

Stereo Separation:

1kHz	More than 40dB
50Hz~10kHz	More than 30dB

Sub Carrier Suppression	65dB
Antenna Input	300Ω Balanced, 75Ω Unbalanced
Muting	ON-OFF

AM SECTION

Sensitivity

(IHF, Ferrite antenna) 300 μ V/m(IHF, Ext. antenna) 15 μ V

Selectivity 40dB

Signal-to-Noise Ratio 50dB

Image Rejection 65dB

IF Rejection 85dB

MISCELLANEOUS

Power Requirements AC 120V 60Hz or 110, 120, 130, 220 and 240V
(switchable) 50/60HzPower Consumption 290W (UL approved model only)
470W (5 line voltage model only)Dimensions 520 (W) x 175 (H) x 420 (D) mm
20-1/2 x 6-7/8 x 16-9/16 in.

Weight:

Without Package 18.5 kg (40 lb 11 oz)

With Package 22.6 kg (49 lb 12 oz)

FURNISHED PARTS

FM T-type Antenna 1

Operating Instructions 1

Fuse 6A 1

Fuse 3A 1

} (5 line voltage model only)

NOTE:

Specifications and the design subject to possible modification without notice due to improvements.

2. FRONT PANEL FACILITIES

FRONT PANEL FACILITIES

SPEAKER BUTTONS

Each of speaker systems A, B, and C is connected to each of output terminals A, B, and C.

By pushing the following:

- SPKR-A Speaker systems A into operation
- SPKR-B Speaker systems B into operation
- SPKR-C Speaker systems C into operation

NOTES:

1. When any two pairs of the buttons (A + B, B + C, C + A) are depressed, the corresponding pairs of speaker systems will come into operation. However, operating all three buttons even though depressed at the same time is not possible.
2. Only when listening through headphones, press again the SPKR button(s) in use to OFF (undepressed) from the ON position (pressed).

POWER SWITCH

Turn this switch ON but wait for some 3 to 6 seconds, during the silence of which the protection circuit eliminates the unpleasant noise not imputed to a receiver fault.

PHONES (1, 2) OUTPUT JACKS

Accept two pairs of headphones.

BASS CONTROLS

Adjust bass tone quality.

- 100Hz For the low frequencies below 400Hz. Possible up to 10dB of increasing or reducing at 100Hz in 2dB steps.
- 50Hz After adjustment by the 100Hz control, further adjust frequencies below 80Hz by this control, if necessary. Possible up to 5dB of increasing or reducing in bass response at 50Hz in 2.5dB steps.

LOW CUT, HIGH CUT BUTTONS

LOW When the low-pitched rumble (turntable motor or other source) is obtrusive, depress the LOW CUT button to ON. In no interference, leave it undepressed (OFF).

HIGH When the high frequency scratch noise (records or other source) is much, depress this button to ON. In no interference, leave it undepressed (OFF).

TONE SWITCH

When in the ON (up) position, this switch causes the amplifier section to operate with a flat frequency regardless of the tone control settings. Use this switch to check the audio characteristics of your listening room such as when it is necessary to check the tone quality of phono cartridges and speakers and also to particularly set the tone controls to be assessed.

SIGNAL METER

For AM and FM station tuning.

- AM tuning: Tune the dial pointer so that the SIGNAL meter needle comes to the extreme right.
- FM tuning: Both the SIGNAL and FM TUNING meters work together. The optimum point of the SIGNAL meter needle is the same as in AM tuning. Then use the FM TUNING meter.

FM TUNING METER

While getting the SIGNAL meter needle going to the right, make fine adjustment with the FM TUNING meter whose needle comes to the center (indicating the optimum reception).

FM STEREO INDICATOR TUNING KNOB

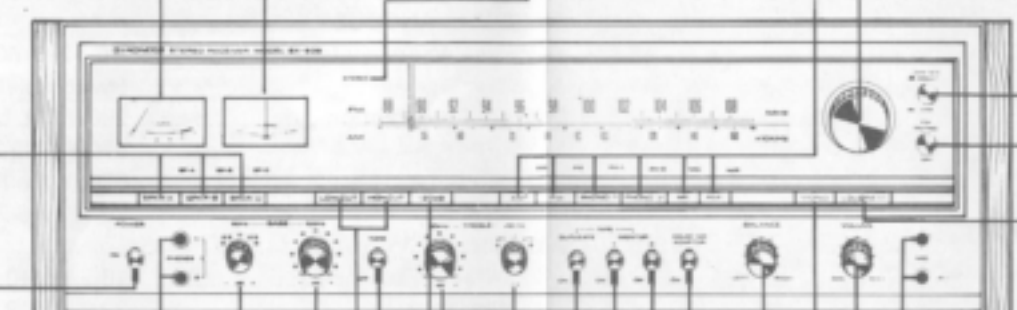

FUNCTION SELECTOR BUTTONS

For selecting the program source, push each button as follows:

- AM For AM broadcast reception.
- FM For FM broadcast reception. The STEREO indicator lights up when the broadcast is in stereo.
- PHONO 1 For operating a turntable connected to the PHONO 1 input jacks.
- PHONO 2 For operating a turntable connected to the PHONO 2 input jacks.
- MIC For using a microphone. Not possible to mix with other program source.
- AUX For listening to audio equipment (cartridge tape player, TV sound tuner, etc.) connected to the AUX input jacks.

DIMMER SWITCH

Dims the brightness of the indicator light. Press again to restore full brightness.

FM MUTING BUTTON

Leave this button undepressed (in the ON position) while tuning in FM stations. Inter-station noise may interfere with FM reception while tuning between stations. To suppress this noise, leave the MUTING button undepressed (in the ON position). If the low signal strength is due to distance from the transmitter or other influences, depress this button, at which the weak station will be heard with the MUTING "OFF."

LOUDNESS BUTTON

Depress this button to listen at low volume. The human ear's frequency response varies according to the listening volume. The depressed button compensates for hearing response with emphasis on the bass and treble.

MIC INPUT JACKS

L, R For connecting the left and right channel microphones.

NOTE:

Use the high impedance (above 20K Ω) with 6mm diam. phone plugs.

VOLUME CONTROL

Governs both the volume of sound outputs from the speaker systems and from the headphones.

MODE BUTTON

Leave this button undepressed (if necessary, depress this to release it when already depressed) for STEREO playback. For MONO playback, depress it. In this case stereo signals for left and right channels will be mixed into mono signal which will be heard from the center of both speaker systems.

TREBLE CONTROLS

Adjust treble tone quality.

- 10kHz For the high frequencies above 2.5kHz. Possible up to 10dB of increasing or reducing in treble response at 10kHz in 2dB steps.
- 20kHz After adjustment by the 10kHz control, further adjust frequencies above 12kHz by this control, if necessary. Possible up to 5dB of increasing or reducing in treble response at 20kHz in 2.5dB steps.

AUDIO MUTING BUTTON -20dB

Depress this button to mute the audio input to -20dB. No need to turn down the VOLUME control on each occasion for your convenience.

TAPE DUPLICATE SWITCH

Leave this switch in the ON (down) position to duplicate or edit a recorded tape using two tape decks. For normal use, switch over to the OFF (up) position.

BALANCE CONTROL

Adjusts the balance between the sound volume from the left and right speaker systems.

TAPE MONITOR (1, 2) SWITCHES

Monitor the recorded sound while recording with a tape deck. Also possible to play back tapes as follows:

- 1 With a tape deck connected to the TAPE 1 jacks (REC and PB), either monitoring of recording in progress or playing back is possible.
- 2 With a tape deck connected to the TAPE 2 jacks (REC and PB or REC/PB connector), the same as in 1 above is possible.

DOLBY NR ADAPTOR SWITCH

When employing Dolby Noise Reduction Adaptor depress this DOLBY NR ADAPTOR to ON.

3. CONNECTION DIAGRAM

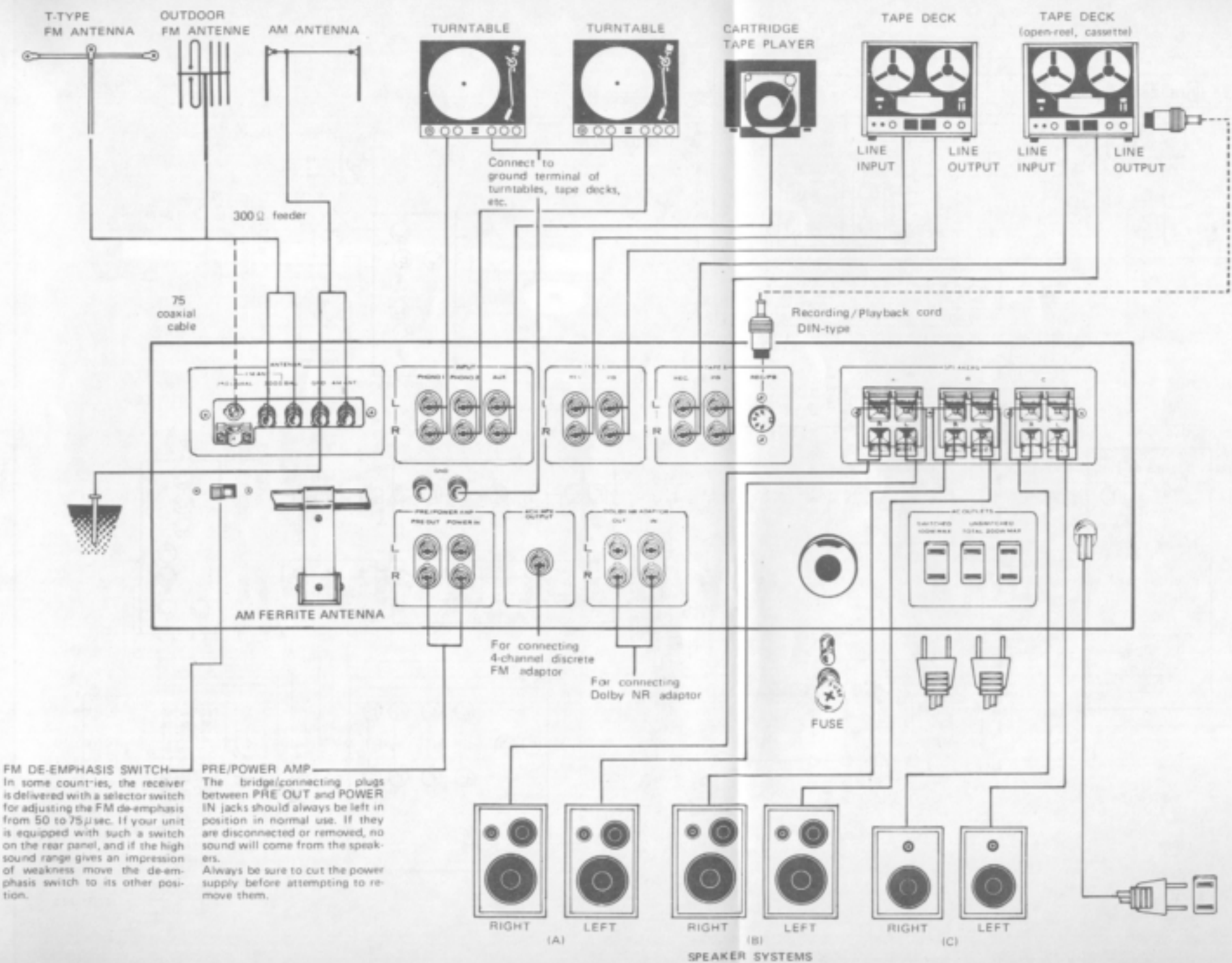

FM DE-EMPHASIS SWITCH
 In some countries, the receiver is delivered with a selector switch for adjusting the FM de-emphasis from 50 to 75µsec. If your unit is equipped with such a switch on the rear panel, and if the high sound range gives an impression of weakness move the de-emphasis switch to its other position.

PRE/POWER AMP
 The bridge/connecting plugs between PRE OUT and POWER IN jacks should always be left in position in normal use. If they are disconnected or removed, no sound will come from the speakers. Always be sure to cut the power supply before attempting to remove them.

SPEAKER SYSTEMS

4. BLOCK DIAGRAM

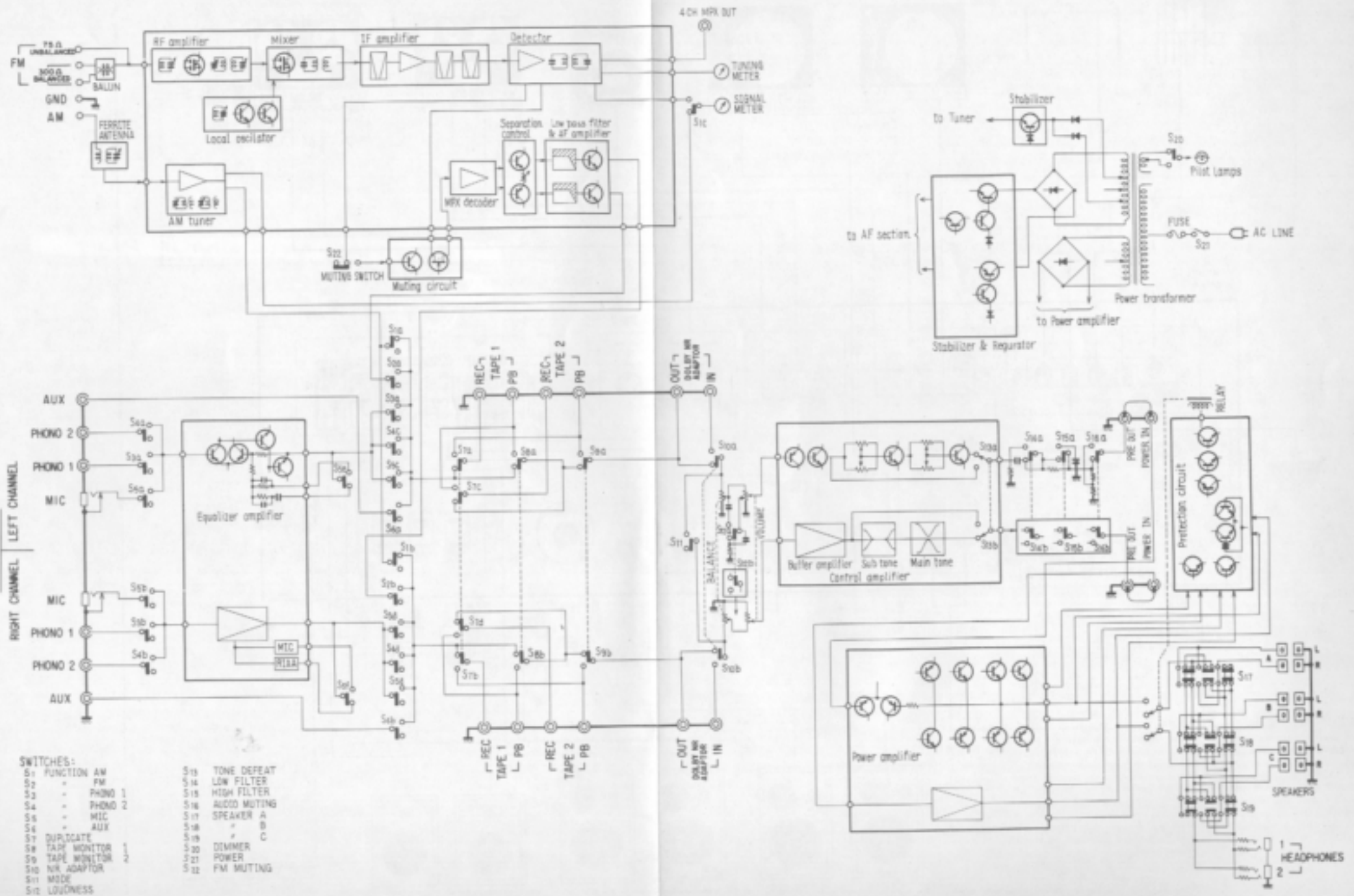

- SWITCHES:**
- S1 FUNCTION AM
 - S2 FM
 - S3 PHONO 1
 - S4 PHONO 2
 - S5 MIC
 - S6 AUX
 - S7 DUPLICATE TAPE MONITOR
 - S8 TAPE MONITOR
 - S9 TAPE MONITOR
 - S10 NR ADAPTOR
 - S11 MODE
 - S12 LOUDNESS
 - S13 TONE DEFEAT
 - S14 LOW FILTER
 - S15 HIGH FILTER
 - S16 AUDIO MUTING
 - S17 SPEAKER A
 - S18 B
 - S19 C
 - S20 DIMMER
 - S21 POWER
 - S22 FM MUTING

5. CIRCUIT DESCRIPTION

SIGNAL PATH

- The FM broadcast signal waveform from the antenna is fed to the two dual-gate MOS field-effect transistor in the front end section for radio frequency amplification. This signal is converted into an intermediate frequency by the dual-gate MOS FET mixer stage in combination with the signal from the local oscillator.
- The intermediate frequency signal, converted within the front end section, is fed to three ceramic filters and two ICs, where it is tuned, amplified, and detected, becoming a audio frequency (composite) signal. The composite signal following detection is fed to the 4 CH MPX terminal jack and the multiplex decoder stage.
- The multiplex decoder stage uses one IC for three functions: to demodulate the composite signal into the left and right channel stereo signals, to operate the automatic mode switching between stereo/mono, and to switch the stereo indicator lamp appropriately. The decoding system uses a phase locked loop (PLL) circuit, which assures continuous stable operation and excellent stereo separation with low susceptibility to external noise (such as car ignition noise) and ambient temperature changes. After decoding, the signal is fed to four transistors and one LC filter, where the residual carrier component (38kHz, 19kHz, and SCA) is rejected, and then to the audio amplifier section.
- The FM muting circuit consists effectively of two circuits, designed to reduce the pulse noise which can so easily arise when a muting circuit is operative. The one circuit is an electronic switch incorporated into the IC, so that the demodulated circuit is switched off and on in the IC, and the other gate circuit the composite signal by means of an FET.
- The AM tuner section employs one monolithic IC which functions as radio frequency amplifier, frequency converter, local oscillator, intermediate frequency amplifier, and detector. The output is a pure audio signal.
- The signals which are applied to the MIC and PHONO terminal jacks are selected by the FUNCTION switch before being fed to the first stage of the three-stage differential direct-coupled equalizer amplifier by which the signals are amplified. In order to reduce the switch noise, the circuit configuration employed enables the potential at the input and output terminals to be set at near zero volts.

It incorporates an independent differential circuit in the first stage of the equalizer amplifier whose DC supply uses twin plus and minus.

- The output from the equalizer amplifier, together with that from the AUX terminal jacks, the audio signal from the AM tuner, and the audio signal from the FM tuner, are all selected by the FUNCTION switch, and pass through the switch circuit for TAPE DUPLICATE, TAPE MONITOR, DOLBY NR ADAPTOR, and the circuits for BALANCE and VOLUME controls, before being fed to the control amplifier.
- The control amplifier has an extremely high input impedance, using PNP and NPN transistors in a two-stage direct-coupled circuit. This greatly reduces the influence of the performance inherent in equipment connected externally. The output from this two-stage direct-coupled circuit is divided into two circuit systems. One goes to the TONE switch via the twin tone control circuit, and the other goes directly and unmodified in any way to the TONE switch. The TONE switch selects between them.
- The amplifier section of the twin control has closed loop NFB amplifiers for both the main and sub circuits, each of which has its own transistor, eliminating mutual interference.
- The control amplifier output is fed to the power amplifier after passing through the LOW FILTER, HIGH FILTER, and AUDIO MUTING circuits. The first stage of the power amplifier is a differential amplifier element, and the second stage uses a constant current load circuit, so that DC potential drift is prevented. On the other hand, the final output stage uses two power transistors in parallel in both the upper and lower circuits, so that large collector dissipation is possible.
- The power amplifier output is fed to the three push buttons which form the SPEAKER switch. This selects A, B, and C speaker system terminal connection. If all three speaker systems were to be connected simultaneously, the effective speaker impedance might be less than 4Ω . To guard against this possibility, when all three buttons are depressed together, all three systems are disconnected from the amplifier.
- The protection circuit which guards against DC potentials at the power amplifier output junctions, against speaker complex load im-

pedances less than 4Ω , and shorts across the speaker terminals. Their operation is such that, under the corresponding abnormal condition, a relay acts to separate the output junction and the output circuit. Further,

this protection circuit also helps to mute the unwanted signal which immediately follows switching the POWER switch ON, and to immediately disconnect the output after switched OFF.

6. LEVEL DIAGRAM

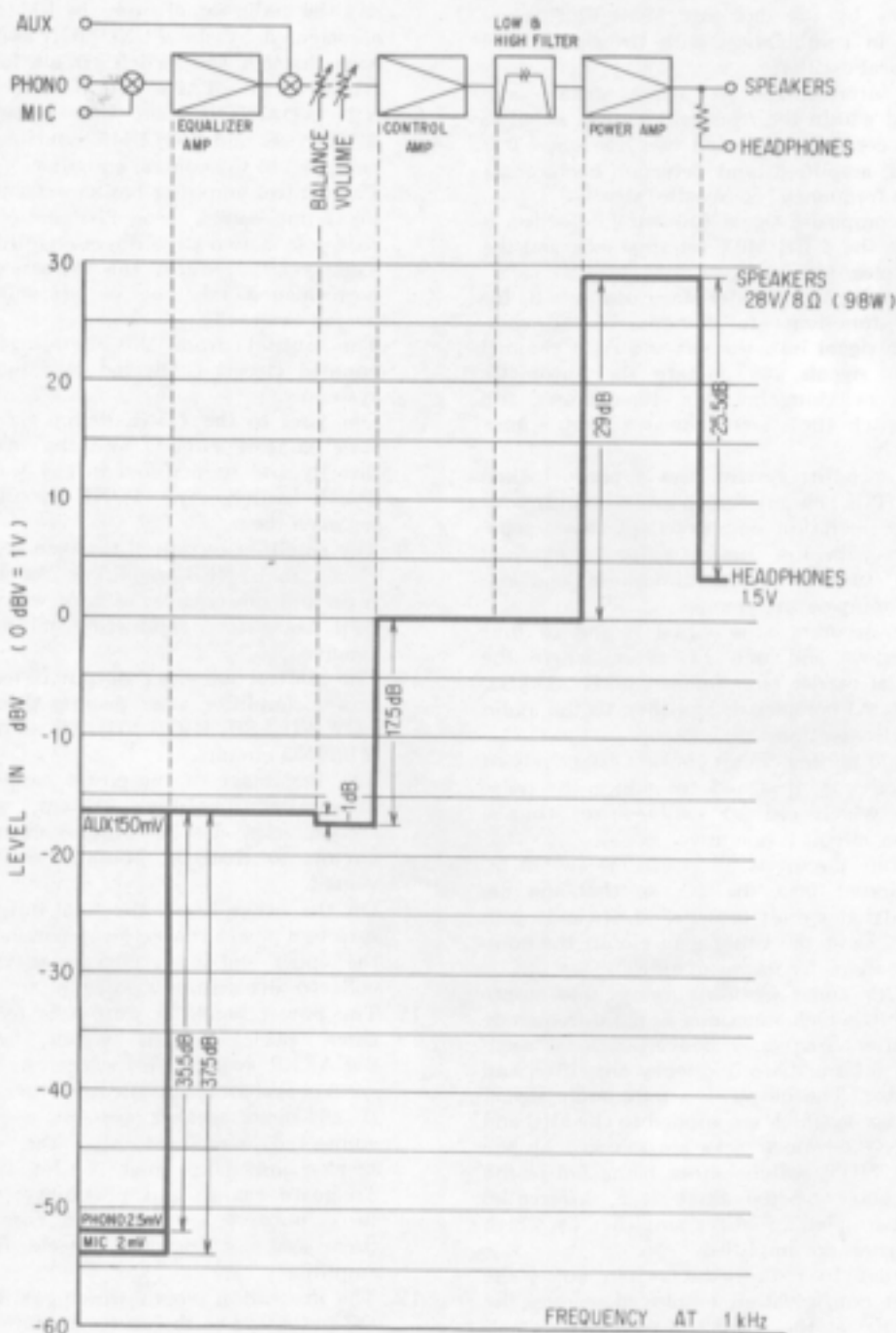

7. DISASSEMBLY

1. To remove the wooden cabinet, first remove the two screws holding each side, then lift the back of the wooden cabinet upward.
2. Pull off all knobs.
3. Remove the two screws in the upper edge of the front panel and remove two nuts and washers. Then pull the panel gently forward.
4. To remove the bottom plate, first remove the ten screws holding it in place.

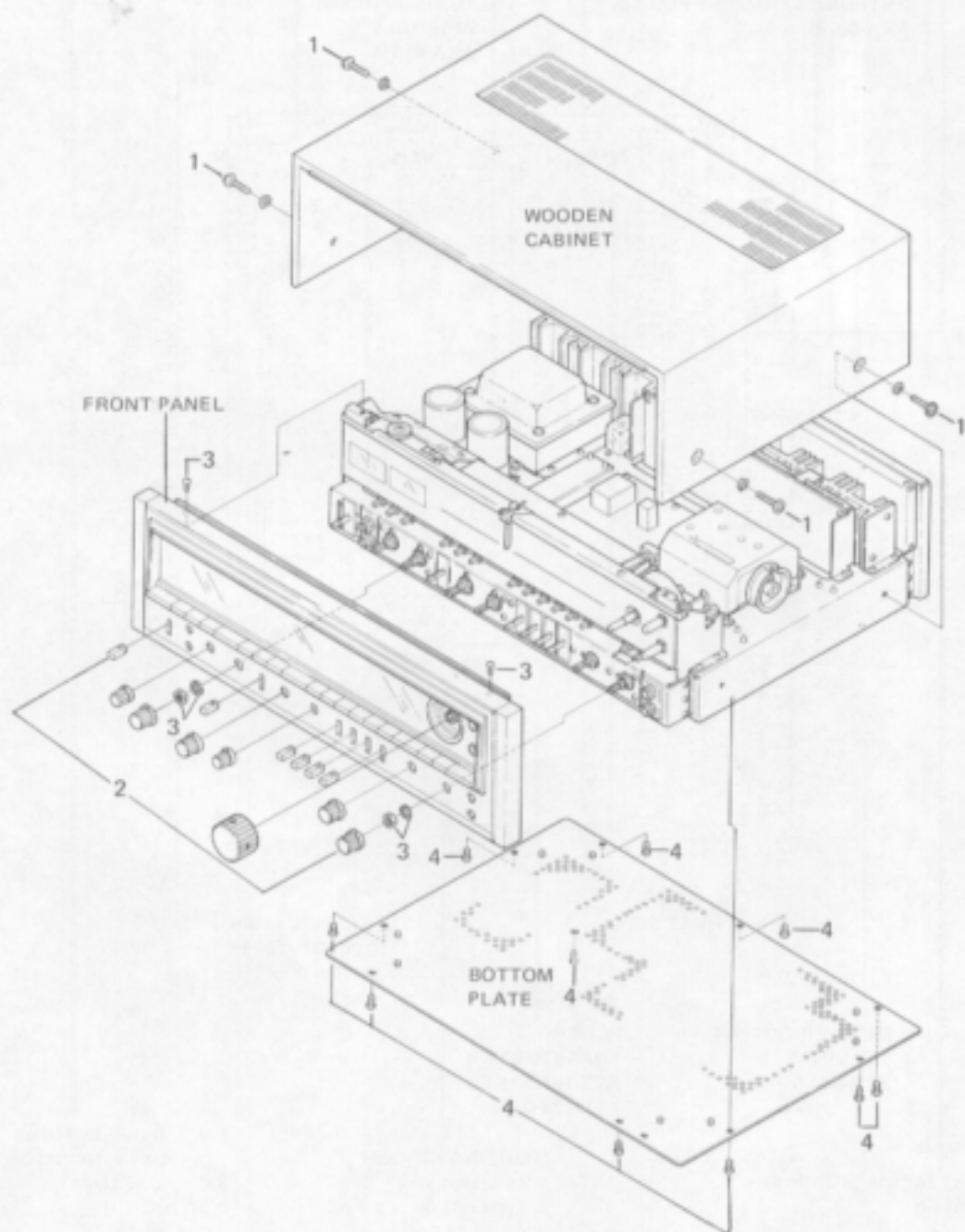

8. PARTS AND P.C. BOARD LOCATIONS

TOP VIEW

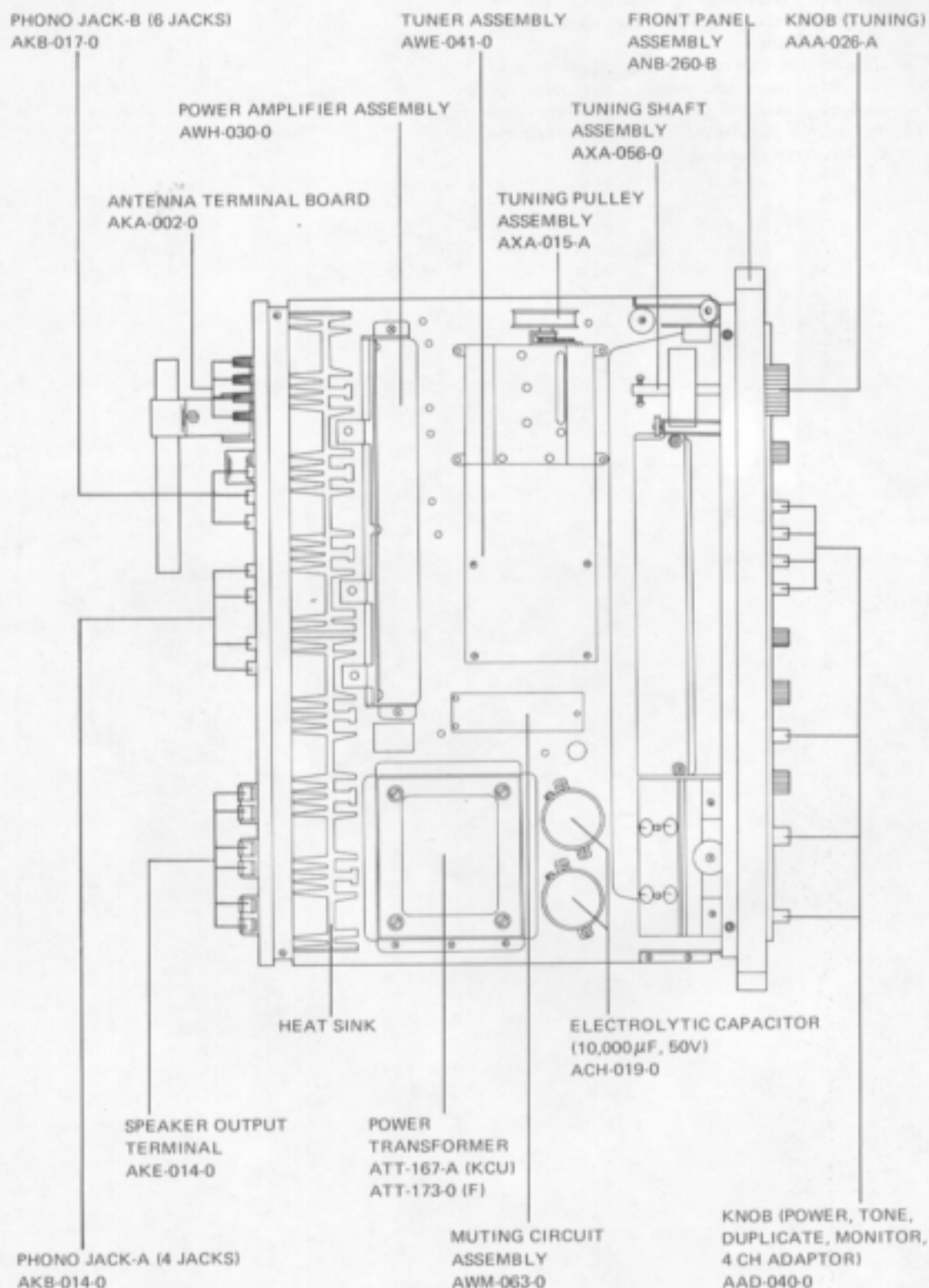

BOTTOM VIEW

ANTENNA CLAMPER
AEC-154-0

KNOB (TREBLE-SUB, BASS-SUB)
AAB-069-B

FUSE HOLDER
AKR-012-0 (KCU)
AKR-001-0 (F)

CONTROL AMPLIFIER
ASSEMBLY
AWG-027-0

POWER SUPPLY CIRCUIT
ASSEMBLY
AWR-052-0

LEVER SWITCH (POWER)
ASK-080-0 (KCU)
ASK-067-0 (F)

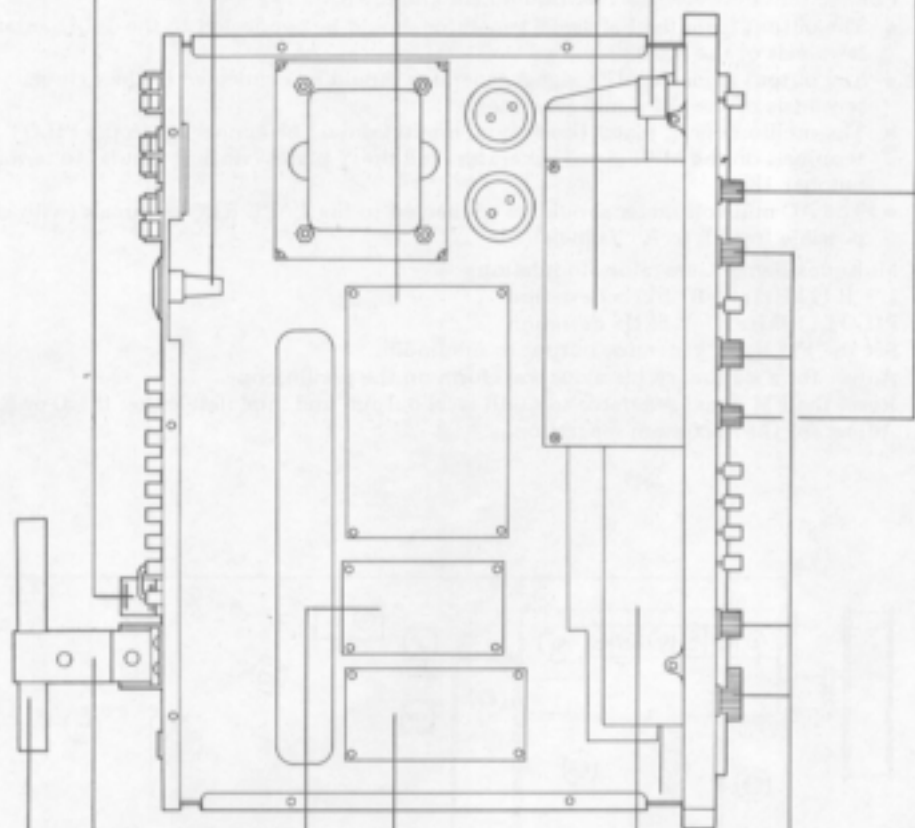

PROTECTION CIRCUIT
ASSEMBLY
AWM-062-0

SWITCH CIRCUIT ASSEMBLY
AWS-067-0

FERRITE ANTENNA
HOLDER ASSEMBLY
AXB-001-A

EQUALIZER AMPLIFIER
ASSEMBLY
AWF-013-0

FERRITE LOOPSTICK
ANTENNA
ATB-026-0

KNOB (TREBLE-MAIN,
BASS-MAIN, VOLUME,
BALANCE)
AAB-068-A

9. DIAL CORD STRINGING

1. Turn the tuning capacitor so that its plates protrude as much as possible.
2. Tie one end of the string to the spring on the TUNING pulley (attached to the tuning capacitor).
3. Lead the string around pulley A, then wind it three turns around the TUNING shaft.
4. Lead the string around pulleys B, C and D, then wind it 1-1/2 turns around the TUNING pulley.
5. Now tie the other end of the string to the spring on the TUNING pulley. Turn the TUNING shaft and check for proper function. Then trim the ends of the string.
6. Turn the TUNING shaft until the plates of the variable are all the way in. Move the pointer to the left-end starting point on the dial and fasten it to the string in that position.

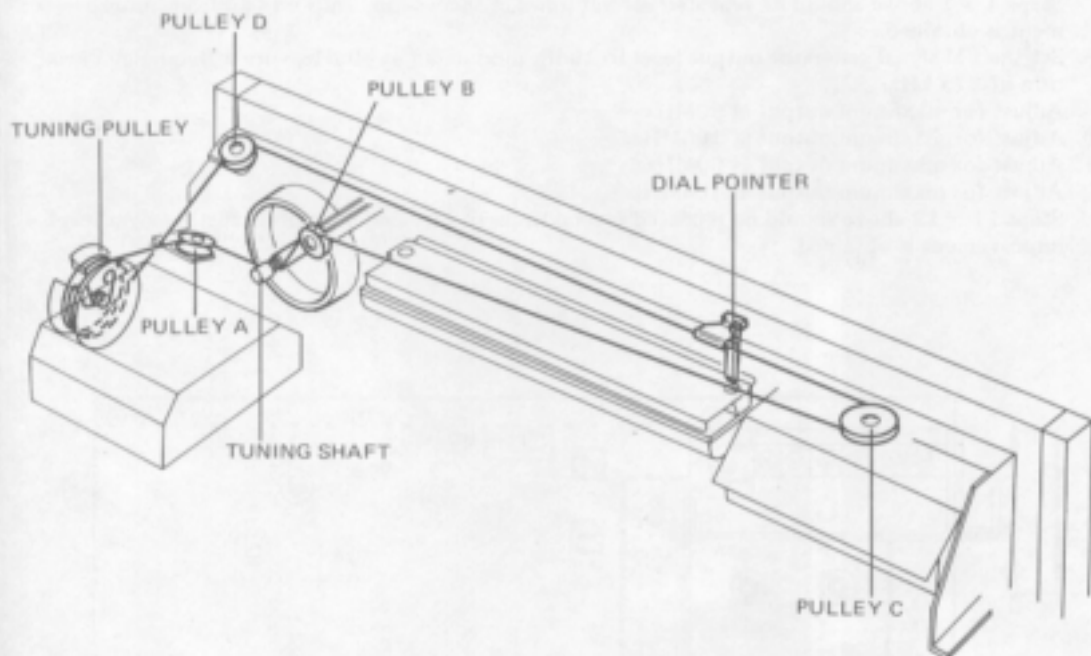

10. ALIGNMENT PROCEDURE

10.1 ENGLISH

ALIGNING THE FM SECTION

1. SX-939 Control Settings

Set the controls (knob and switches) of the SX-939 as follows:

- POWER: ON
- FUNCTION: FM
- FM MUTING: OFF

2. Connections between Test Equipment and the SX-939

- The output from an FM signal generator should be connected to the 300Ω antenna terminals of the SX-939.
- A distortion meter should be connected to the TAPE REC terminal jacks on the SX-939.
- An AC millivolt meter should be connected to the TAPE REC terminal jacks on the SX-939 in parallel with the distortion meter.

3. Set both the FM signal generator and the SX-939 to indicate 98MHz.

4. Turn the FM signal generator output level down to minimum.

5. Turn the lower core and adjust so that the TUNING meter needle is centered.

6. Increase the FM signal generator output to 60dB, modulated at 400Hz, with a deviation of ±75 kHz.

7. Turn the upper core and adjust so that the distortion is at a minimum.

Steps 4 ~ 7 above should be repeated several times in succession, until no significant improvement is obtained.

8. Set the FM signal generator output level to 10dB, modulated at 400Hz, with a frequency deviation of ±75 kHz.

9. Adjust for maximum output at 90MHz.

10. Adjust for maximum output at 106MHz.

11. Adjust for maximum output at 90MHz.

12. Adjust for maximum output at 106MHz.

Steps 11 ~ 12 above should be repeated several times in succession, until no further significant improvement is obtained.

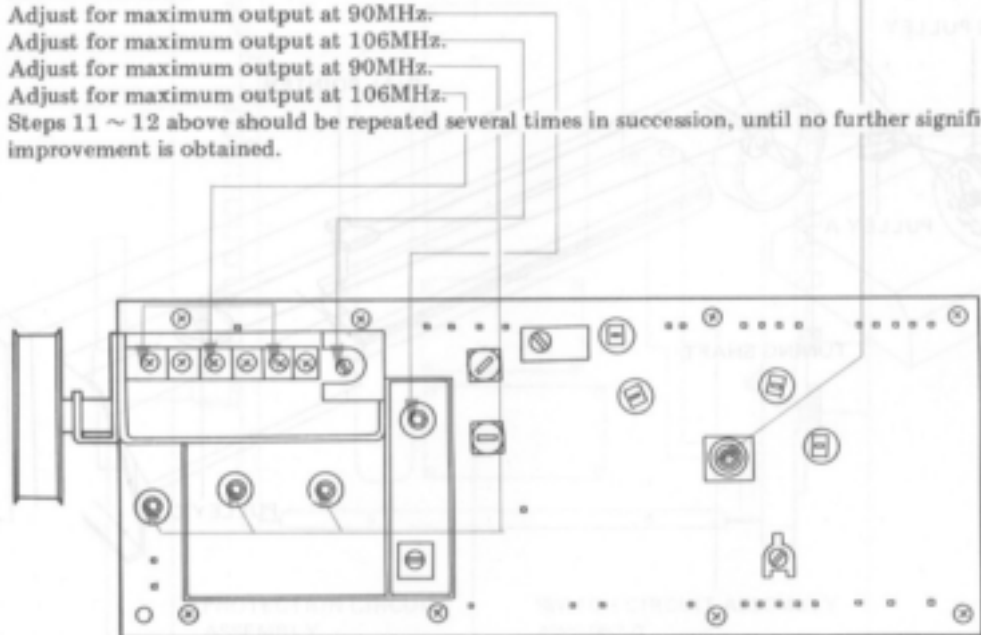

ALIGNING THE FM MPX SECTION

Notes: This set of adjustments should not be carried out until the alignment of the FM section (1 ~ 12 above) has been completed.

The multiplex signal generator should be connected to the external modulator terminals of the FM signal generator.

1. SX-939 Control Settings

Set the controls (knob and switch) of the SX-939 as follows:

POWER: ON

FUNCTION: FM

FM MUTING: OFF

2. Connections between the Test Equipment and the SX-939

- The output from the FM signal generator should be connected to the 300Ω antenna terminals of the SX-939.
- The output from the MPX signal generator should be connected to the external modulator terminals of the FM signal generator.
- The oscilloscope X plates (horizontal inputs) should be connected to the PILOT OUT terminals on the MPX signal generator, and the Y plates (vertical inputs) to terminal number 18.
- The AC millivolt meter should be connected to the TAPE REC terminals (with changeover possible from L to R channels).

3. Multiplex Signal Generator Modulation

L + R (1kHz): 67.5kHz deviation

PILOT (19kHz): 7.5kHz deviation

4. Set the FM signal generator output to minimum.

5. Adjust for a stationary Lissajous waveform on the oscilloscope.

6. Reset the FM signal generator to 60dB level output, and modulate either the L or R channel.

7. Adjust for the maximum separation.

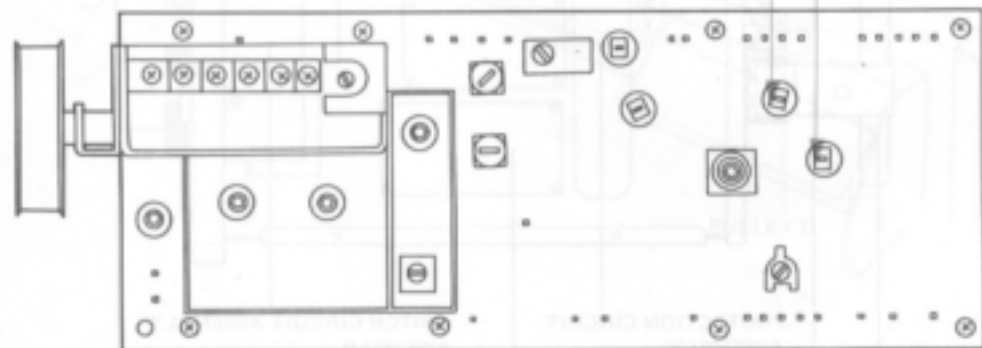

ALIGNING THE AM SECTION

1. SX-939 Control Settings

Set the controls (knob and switch) of the SX-939 as follows:

POWER: ON

FUNCTION: AM

2. Connections between Test Equipment and the SX-939

- Connect the AM signal generator to the AM antenna terminals (in series with a $1\text{ k}\Omega$ dummy resistor).

- Connect the AC millivolt meter to the TAPE REC terminal jacks.

3. Set the AM signal generator to 30% modulation at 400Hz.

4. Set the AM signal generator output to 30dB at 600kHz.

Adjust for maximum output (Carry out the ferrite loopstick antenna core adjustment at the same time).

5. Adjust for maximum output with the frequency set at 1,400kHz.

Adjustments 4 ~ 5 above should be repeated several times until no further significant improvement is obtained.

6. Connect the AM signal generator directly to the AM ANT (antenna) terminals.

7. With a frequency of 1,400kHz and an AM signal generator output of 36dB, adjust for a low frequency output of 70mV.

8. With an AM signal generator output of 80dB, adjust for a low frequency output of 310mV.

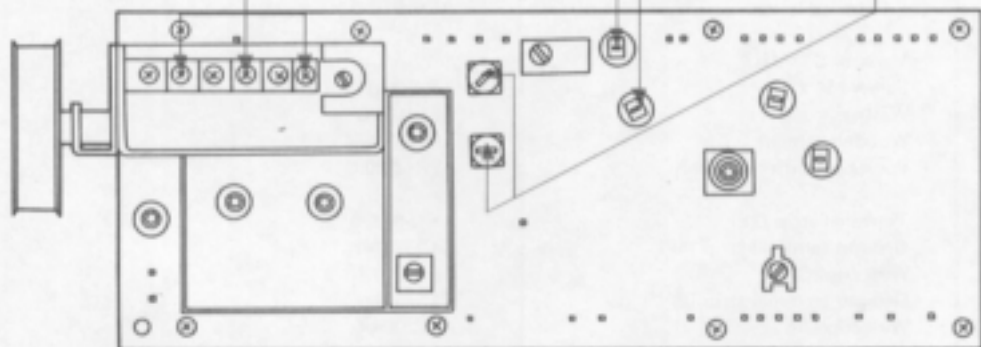

ALIGNING THE POWER AMPLIFIER SECTION

1. Nothing should be connected to the input jacks of the SX-939, and an 8Ω dummy resistor should be connected across the speaker terminals.

2. A DC millivolt meter should be connected across between terminal number 10 (25) and earth.

3. Adjustment should be made to bring the voltage to zero.

4. The DC voltmeter should be connected between terminals number 50 (38) and 44 (32).

5. Adjustment should be made to bring the voltage to 50mV.



11. EXPLODED VIEW AND PARTS LIST

NOTE:

Parts number is subject to change for the purpose of improvement with notice of a service bulletin.

Service bulletin will be furnished whenever necessary and you are requested to amend parts number in this manual according to the instructions.

Parts List of Exploded View-1

NOTICE: Any parts asterisked(*) are subject to being not supplied.

Key No.	Description	Part No.	
1	Power transformer	ATT-167-A	KCU
	Power transformer	ATT-173-0	F
	Power transformer	ATT-180-A	GN
2*	Power transformer-held metal	ANF-248-0	
3	Electrolytic capacitor 10,000 μ F 50V	ACH-019-0	
4	Foot	AEC-027-B	
5*	Bottom plate	ANE-055-B	
6*	Heat sink-held metal	ANF-231-0	
7*	Heat sink	ANH-215-A	
8*	Heat sink-held metal	ANF-232-0	
9	Muting circuit assembly	AWM-063-0	
10*	P.C. board holder	AEB-019-0	
11	Varistor STV4H		
12	Screw M4 x 15	ABA-010-A	
13	Washer	B21-011-0	
14	Wooden cabinet	AMM-035-A	
15	Power amplifier assembly	AWH-030-0	
16	Terminal strip (2P)	AKC-015-0	
17	Ground terminal strip (4P)	K13-047-0	
18*	Wire clip (C)	AEC-007-0	
19	Ground terminal strip (2P)	K13-048-0	
20*	Wire clip (A)	AEC-004-0	
21*	Chassis	ANA-068-B	
22*	Wire clip	AEC-064-0	
23	Power supply circuit assembly	AWR-052-0	KCU, F
	Power supply circuit assembly	AWR-056-0	GN
24	Relay	ASR-007-0	
25	Protection circuit assembly	AWM-062-0	
26	Equalizer amplifier assembly	AWF-013-0	
27*	Shield cover	ANF-240-A	
28	Tuner assembly	AWE-041-0	
29	Tuning pulley assembly	AXA-015-A	
30*	P.C. board-held metal (A)	ANF-246-A	
31*	P.C. board-held metal (B)	ANF-247-A	

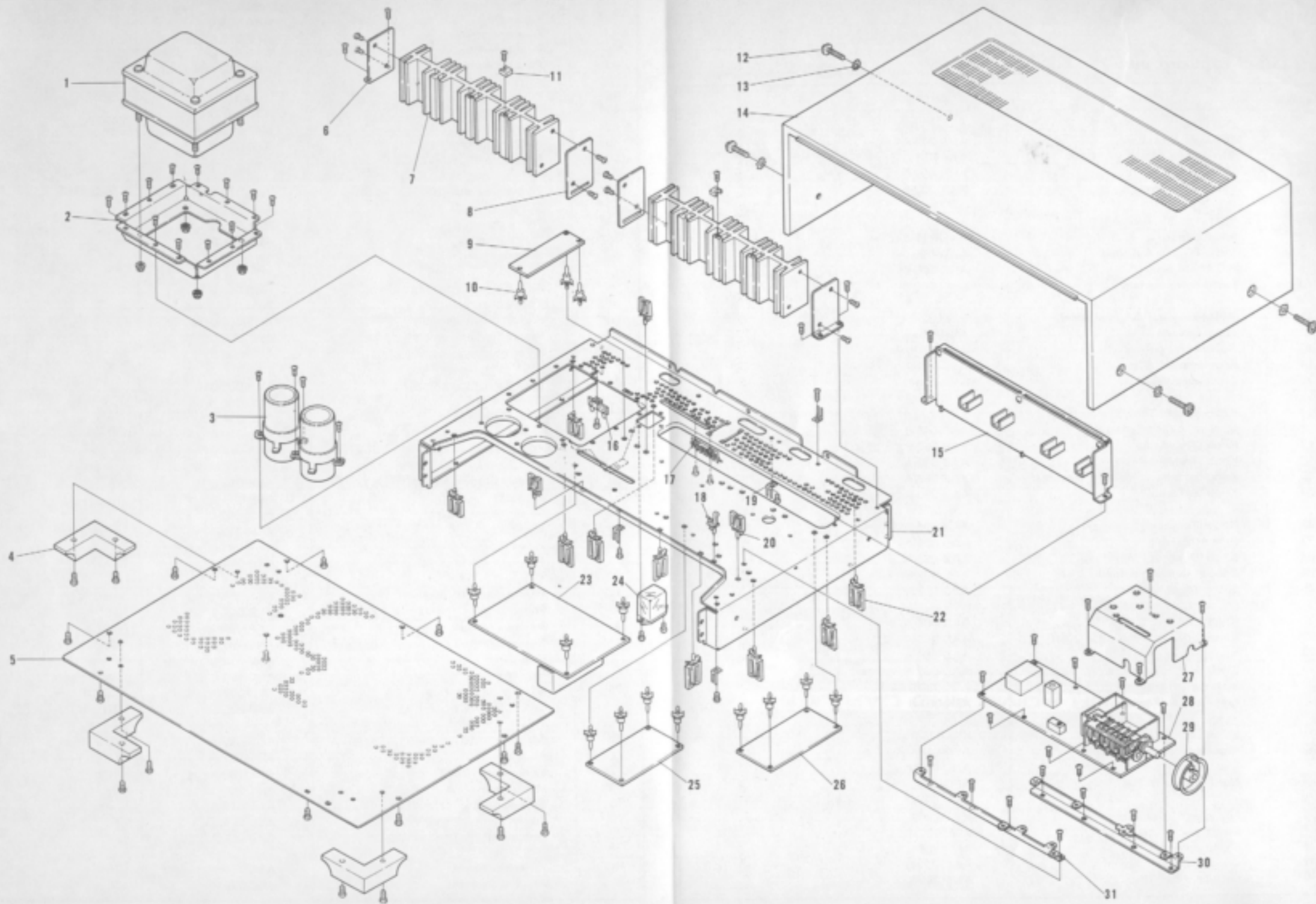

NOTE:

Parts number is subject to change for the purpose of improvement with notice of a service bulletin.

Service bulletin will be furnished whenever necessary and you are requested to amend parts number in this manual according to the instructions.

Parts List of Exploded View-2

NOTICE: Any parts asterisked(*) are subject to being not supplied

Key No.	Description	Part No.	
1	Dial scale	AAG-074-A	
2*	Dial scale-held metal	ANF-243-A	
3	Dial pointer assembly	AAF-031-A	
4	Lamp holder	ANG-097-0	
5	Pilot lamp socket	AKK-002-0	
6	Pilot lamp 8V, 0.3A (meter)	AEL-015-0	
7*	Lamp box (B)	ANH-211-B	
8	Meter (Tuning & Signal)	AAW-029-0	
9	P.C. board cover	ANG-100-0	
10	Lamp board assembly	AWX-069-0	
11	Pilot lamp 8V, 0.3A (dial scale)	E22-032-0	
12*	Lamp box (A)	ANH-210-A	
13	Rubber bracket	AEB-031-0	
14	Pilot lamp 8V, 50mA	AEL-014-0	
15	Front panel assembly	ANB-260-B	
16	Knob (Power, Tone, Duplicate, Monitor, 4-CH adaptor)	AAD-040-0	
17	Knob (Treble-sub)	AAB-069-B	
18	Knob (Treble-main)	AAB-068-A	
19	Knob (Bass-main, Volume, Balance)	AAB-068-A	
20	Knob (Bass-sub)	AAB-069-B	
21	Knob (Tuning)	AAA-026-A	
22	Ornamental ring	AAC-034-A	
23	Knob (Dimmer, FM muting)	AAD-082-A	
24	Coupler (knob-to-switch)	AAE-007-0	
25	Spacer (push knob)	AEC-152-A	
26	Knob (SPKR A, B, C)	AAD-064-A	
27	Knob (Low cut, High cut, -20dB)	AAD-065-A	
28	Knob (Function)	AAD-066-A	
29	Knob (Mode, Loudness)	AAD-067-A	
30	Lever switch (Power)	ASK-080-0	KCU
	Lever switch (Power)	ASK-067-0	F
31	Phone jack (Headphone)	K72-026-0	
32	Shading plate	AED-018-0	
33*	Dial frame	AND-072-A	
34	Nut (insulator)	AEC-085-0	
36	Phone jack (Microphone)	K72-024-0	
37	Switch circuit assembly	AWS-067-0	
38*	Shield cover	ANH-206-0	
39	Control amplifier assembly	AWG-027-0	
40*	Shading metal	ANF-249-0	

NOTICE: Any parts asterisked(*) are subject to being not supplied.

Key No.	Description	Part No.	
41*	Pulley	AEC-153-0	
42*	Pulley shaft	ABA-004-0	
43	Rubber bracket	AEB-057-A	
44	Pilot lamp 8V, 50mA	AEL-023-0	
45	Pilot lamp holder (A)	ANG-103-0	
46	Pulley-held metal	ANG-102-A	
47*	Pulley (small)	AEC-101-0	
48*	Pulley shaft	M49-025-E	
49	Rubber bracket	AEB-057-A	
50	Pilot lamp 8V, 50mA	AEL-022-0	
51*	Pilot lamp holder (B)	ANG-104-0	
52*	Sub panel	AND-073-B	
53*	Pulley shaft	M49-025-E	
54*	Pulley (small)	AEC-101-0	
55*	Shading metal	ANF-249-0	
56	Switch circuit assembly	AWS-068-0	
57	Tuning shaft assembly	AXA-056-0	
58	Switch circuit assembly	AWS-064-0	
59	Switch circuit assembly	AWS-066-0	
60	Switch circuit assembly	AWS-069-0	
61	Switch circuit assembly	AWS-065-0	
62*	Shield cover (rear)	ANH-208-A	
63	Phono jack-A (4 jacks)	AKB-014-0	
64	Phono jack (1 jack)	AKB-019-0	
65	Phono jack-A (4 jacks)	AKB-014-0	
66	Speaker output terminal	AKE-014-0	
67	AC socket	AKP-005-0	KCU, F
68	SP connector assembly	AWX-062-0	
69	Fuse holder	AKR-012-0	KCU
	Fuse holder	AKR-001-0	F
70	Phono jack-A (4 jacks)	AKB-014-0	
71	Phono jack-A (4 jacks)	AKB-014-0	
72	Phono jack-B (6 jacks)	AKB-017-0	
73	Antenna terminal board	AKA-002-0	
74*	Rear panel	ANC-107-B	KCU
	Rear panel	ANC-112-A	F
	Rear panel	ANC-114-0	GN
75	AC cord grommet	AEC-079-0	KCU, F
	Connector (AC power)	AKP-008-0	GN
76	AC power cord	ADG-005-A	KCU
	AC power cord	ADG-002-A	F
77*	Model name plate	AAL-180-A	KCU
	Model name plate	AAL-201-0	F
78	Binding post for ground	AKE-012-A	
79	Ferrite loopstick antenna	ATB-026-0	
80	Ferrite antenna holder assembly	AXB-001-A	
81	Antenna clasper	AEC-154-0	
82	AC cord grommet	AEC-079-0	

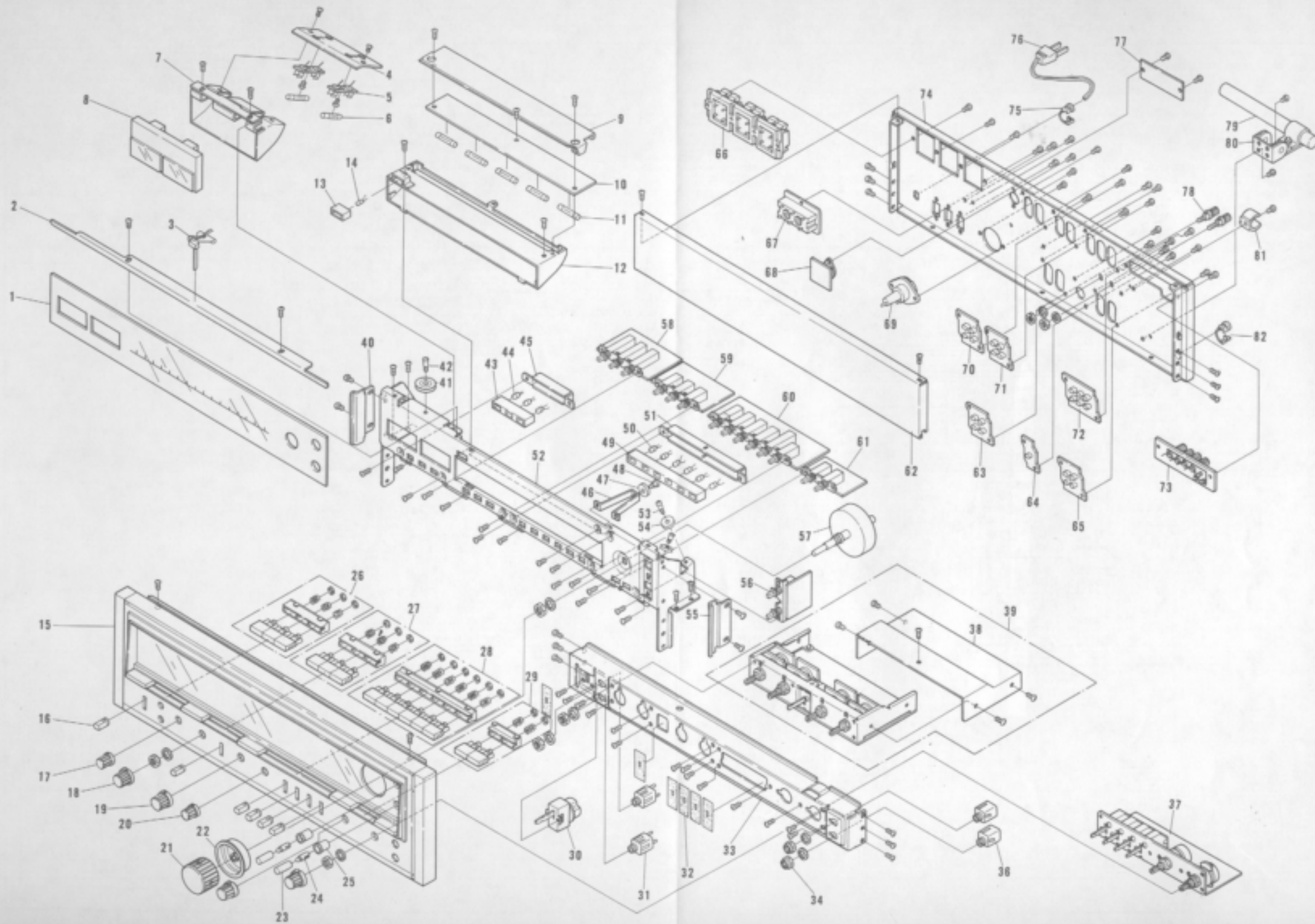

2. SCHEMATIC DIAGRAMS, P.C. BOARD PATTERNS AND PARTS LIST

2.1 CIRCUIT CONNECTION DIAGRAM AND MISCELLANEOUS PARTS

2SA745A
2SB530S
2SB541P
2SC1403A
2SD370S
2SD388P

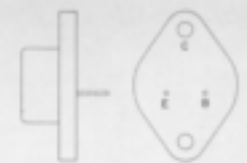

120V ONLY MODEL AND 5 LINE VOLTAGE MODEL

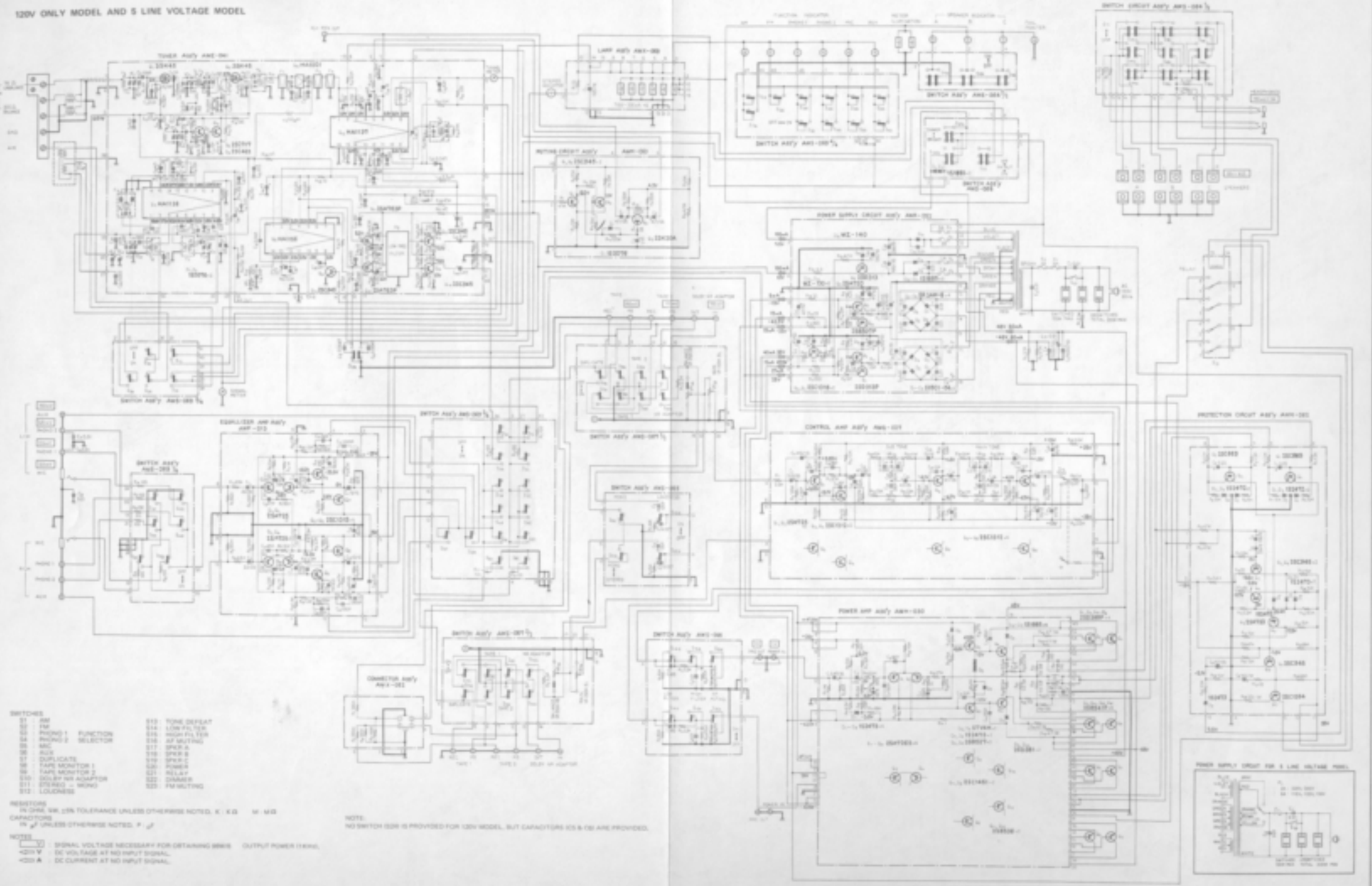

- SWITCHES**
- SW1 POWER
 - SW2 TUNING 1 FUNCTION
 - SW3 TUNING 2 SELECTOR
 - SW4 ALL
 - SW5 DUPLICATOR
 - SW6 TAPES MONITOR 1
 - SW7 TAPES MONITOR 2
 - SW8 SOLID STATE ADAPTOR
 - SW9 STEREO - MONO
 - SW10 LOUDNESS
 - SW11 TIME DISPLAY
 - SW12 LOW PASS FILTER
 - SW13 HIGH PASS FILTER
 - SW14 SPEAKERS
 - SW15 SPEAKERS
 - SW16 SPEAKERS
 - SW17 RELAY
 - SW18 DIMMER
 - SW19 FM MUTING

RESISTORS
IN OHMS, 5% TOLERANCE UNLESS OTHERWISE NOTED. K = 1,000 M = 1,000,000
CAPACITORS
IN P.F. UNLESS OTHERWISE NOTED. P = 100 P.F.

NOTES
① SIGNAL VOLTAGE NECESSARY FOR OBTAINING 800MW OUTPUT POWER (TYP.)
② 120V DC VOLTAGE AT NO INPUT SIGNAL.
③ 200mA DC CURRENT AT NO INPUT SIGNAL.

NOTE:
NO SWITCH SW6 IS PROVIDED FOR 120V MODEL, BUT CAPACITORS C51 & C52 ARE PROVIDED.

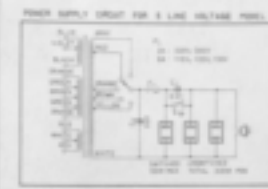

- CAPACITORS: IN μ F UNLESS OTHERWISE NOTED p: pF.
- RESISTORS: IN Ω , %W UNLESS OTHERWISE NOTED k: k Ω , M: M Ω .

Miscellaneous Parts

CAPACITORS

Symbol	Description	Part No.	
C1	Ceramic 0.01 250V	ACG-001-0	KCU F
C2	Ceramic 0.01 250V	ACG-003-0	
	Ceramic 0.01 250V	ACG-001-0	
C3	Electrolytic 10,000 50V	ACH-019-0	
C4	Electrolytic 10,000 50V	ACH-019-0	
C5	Mylar 0.0047 50V	QOMA 472J 50	
C6	Mylar 0.0047 50V	QOMA 472J 50	
C7	Ceramic 0.01 50V	CKDYF 103Z 50	
C8	Ceramic 0.01 50V	CKDYF 103Z 50	
C9	Ceramic 0.01 50V	CKDYF 103Z 50	
C10	Ceramic 0.01 150V	ACG-004-0	

RESISTORS

Symbol	Description	Part No.	
R1	Carbon film 2.2M %W	PR%PS 225J	
R2	Metal oxide 2.7k 2W	RS2P 272J	
R3	Metal oxide 2.7k 2W	RS2P 272J	

SEMICONDUCTORS

Symbol	Description	Part No.	
Q1	Transistor 2SD388P-L or M (2SC1403A-R, O or Y) (2SD370S-R, O or Y)		
Q2	Transistor 2SD388P-L or M (2SC1403A-R, O or Y) (2SD370S-R, O or Y)		
Q3	Transistor 2SB541P-L or M (2SA745A-R, O or Y) (2SB530S-R, O or Y)		
Q4	Transistor 2SB541P-L or M (2SA745A-R, O or Y) (2SB530S-R, O or Y)		
Q5	Transistor 2SB541P-L or M (2SA745A-R, O or Y) (2SB530S-R, O or Y)		
Q6	Transistor 2SB541P-L or M (2SA745A-R, O or Y) (2SB530S-R, O or Y)		
Q7	Transistor 2SD388P-L or M (2SC1403A-R, O or Y) (2SD370S-R, O or Y)		
Q8	Transistor 2SD388P-L or M (2SC1403A-R, O or Y) (2SD370S-R, O or Y)		

Continued on the Next Page

SWITCHES

Symbol	Description	Part No.	
	Lever switch (Power)	ASK-080-0	KCU
	Lever switch (Power)	ASK-067-0	F
	Relay	ASR-007-0	
	Fuse holder	AKR-012-0	KCU
	Fuse holder	AKR-001-0	F
	Slide switch (de-emphasis)	ASH-008-0	F

OTHERS

Symbol	Description	Part No.	
	Tuner assembly	AWE-041-0	
	Power amplifier assembly	AWH-030-0	
	Control amplifier assembly	AWG-027-0	
	Equalizer amplifier assembly	AWF-013-0	
	Protection circuit assembly	AWM-062-0	
	Power supply circuit assembly	AWR-052-0	
	Switch circuit assembly (function)	AWS-069-0	
	Switch circuit assembly (speakers)	AWS-064-0	
	Switch circuit assembly (mode, loudness)	AWS-065-0	
	Switch circuit assembly (filters)	AWS-066-0	
	Switch circuit assembly (tape monitor)	AWS-067-0	
	Switch circuit assembly (dimmer)	AWS-068-0	
	Lamp board assembly	AWX-069-0	
	SP connector assembly	AWX-062-0	
	Muting circuit assembly	AWM-063-0	
	Front panel assembly	ANB-260-B	
	Wooden cabinet assembly	AMM-035-A	
	Foot	AEC-027-B	
	Tuning shaft assembly	AXA-056-0	
	Tuning pulley assembly	AXA-015-A	
	Ferrite antenna holder assembly	AXB-001-A	
	Dial pointer assembly	AAF-031-A	
	Dial scale	AAG-074-A	
	Meter (Tuning and Signal)	AAW-029-0	
	Knob (Tuning)	AAA-026-A	
	Knob (Bass-main, Treble-main, Volume, Balance)	AAB-068-A	
	Knob (Bass-sub, Treble-sub)	AAB-069-B	
	Knob (Power, Tone, Duplicate, Monitor, 4-CH adaptor)	AAD-040-0	
	Knob (SPKR A, B, C)	AAD-064-A	
	Knob (Low cut, High cut, -20dB)	AAD-065-A	
	Knob (Function)	AAD-066-A	
	Knob (Mode, Loudness)	AAD-067-A	
	Coupler (Knob-to-switch)	AAE-007-0	
	Knob (Dimmer, FM muting)	AAD-082-A	
	Phono jack-B (6 jacks)	AKB-017-0	
	Phono jack-A (4 jacks)	AKB-014-0	
	Phono jack (1 jack)	AKB-019-0	
	Antenna terminal board	AKA-002-0	

Symbol	Description	Part No.	
	Binding post for ground	AKE-012-A	
	Power transformer	ATT-167-A	KCU
	Power transformer	ATT-173-0	F
	Ferrite loopstick antenna	ATB-026-0	
	Balun	T22-025-A	
	Fuse 5A (AC power)	AEK-021-0	KCU
	Fuse 3A (AC power)	AEK-101-0	F
	Pilot lamp 8V, 50mA (stereo indicator)	AEL-014-0	
	Pilot lamp 8V, 0.3A (dial scale)	E22-032-0	
	Pilot lamp 8V, 0.3A (meter)	AEL-015-0	
	Pilot lamp 8V, 50mA (program indicator)	AEL-022-0	
	Pilot lamp 8V, 50mA (program indicator)	AEL-023-0	
	Fuse 1A (protection)	AEK-106-0	
	Fuse 3A (protection)	AEK-101-0	
	Fuse 5A (protection)	AEK-039-0	KCU
	AC socket	AKP-005-0	
	Speaker output terminal	AKE-014-0	
	Phone jack (Headphone)	K72-026-0	
	Phone jack (Microphone)	K72-024-0	
	Socket (power transistor)	AKH-001-0	
	Jumper plug	AKM-004-A	
	Pilot lamp socket	AKK-002-0	
	AC cord grommet	AEC-079-0	
	Spacer (insulator)	AEC-076-0	
	Screw M4 x 15	ABA-010-A	
	AC power cord	ADG-005-A	KCU
	AC power cord	ADG-002-A	F
	Operating instructions	ARB-099-0	
	FM T-type antenna	ADH-002-0	
	Packing case	AHD-212-A	
	Side pad (L)	AHA-066-A	
	Side pad (R)	AHA-067-A	
	Inside packing	AHC-014-A	

3SK45

2SC461
2SC717

2SA725

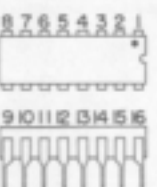

HA1201

HA1137
HA1138

HA1156

2SA763P
2SC945

Foil Side

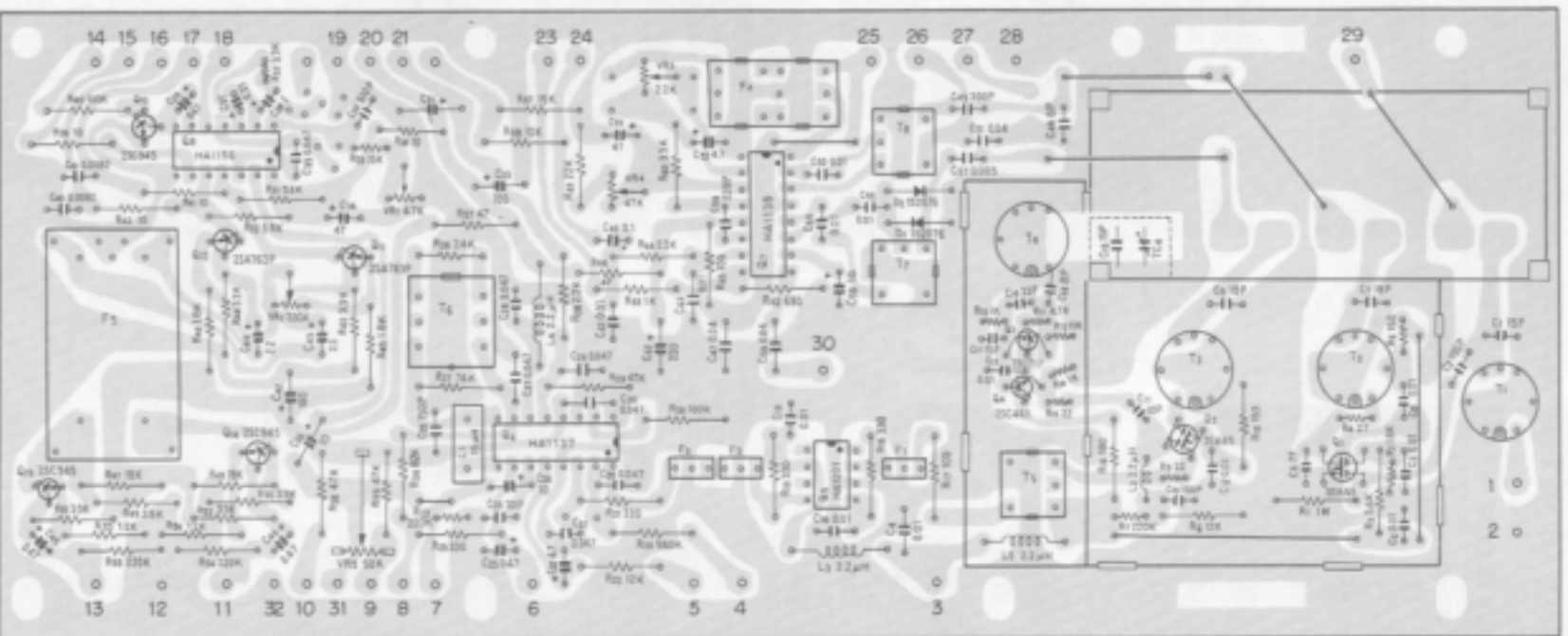

Parts List of Tuner Assembly (AWE-041-0)

CAPACITORS

Symbol	Description			Part No.
C1	Ceramic	15p	50V	CCDSH 150K 50
C2	Ceramic	100p	50V	CCDSL 101K 50
C3	Ceramic	0.01	50V	CKDYF 103Z 50
C4	Ceramic	0.01	50V	CKDYF 103Z 50
C5	Ceramic	2p	50V	CCDSL 020C 50
C6	Ceramic	0.01	50V	CKDYF 103Z 50
C7	Ceramic	18p	50V	CCDSH 180K 50
C8	Ceramic	0.01	50V	CKDYF 103Z 50
C9	Ceramic	18p	50V	CCDSH 180K 50
C10	Ceramic	100p	50V	CCDSL 101K 50
C11	Ceramic	10p	50V	CCDSL 100F 50
C12	Ceramic	0.01	50V	CKDYF 103Z 50
C13	Ceramic	0.01	50V	CKDYB 103K 50
C14	Ceramic	8p	50V	CCDLH 080F 50
C15	Ceramic	15p	50V	CCDLH 150K 50
C16	Ceramic	33p	50V	CCDCH 330K 50
C17	Ceramic	15p	50V	CCDCH 150K 50
C18	Ceramic	0.01	50V	CKDYF 103Z 50
C19	Ceramic	0.01	50V	CKDYF 103Z 50
C20	Ceramic	0.047	25V	CKDBC 473Z 25
C21	Ceramic	0.047	25V	CKDBC 473Z 25
C22	Electrolytic	4.7	25V	CEA 4R7P 25
C23	Ceramic	33p	50V	CCDSL 330K 50
C24	Electrolytic	10	16V	CEA 100P 16
C25	Electrolytic	0.47	50V	CEA R47P 50
C26	Electrolytic	10	16V	CEA 100P 16
C27	Ceramic	0.047	25V	CKDBC 473Z 25
C28	Ceramic	0.047	25V	CKDBC 473Z 25
C29	Ceramic	0.047	25V	CKDBC 473Z 25
C30	Ceramic	0.047	25V	CKDBC 473Z 25
C31	Electrolytic	1	50V	CEA 010P 50
C32	Ceramic	150p	50V	CCDSL 151K 50
C33	Electrolytic	100p	16V	CEA 101P 16
C34	Electrolytic	47	16V	CEA 470P 16
C35	Mylar	0.047	50V	QOMA 473K 50
C36	Styrol	510p	50V	QOSH 511J 50
C37	Electrolytic	0.33	25V	CSSA R33M 25
C38	Electrolytic	1	10V	CSSA 010M 10
C39	Electrolytic	0.47	25V	CSSA R47M 25
C40	Mylar	0.0082	50V	QOMA 822J 50
C41	Mylar	0.0082	50V	QOMA 822J 50
C42	Electrolytic	100	16V	CEA 101P 16
C43	Electrolytic	2.2	25V	CEA 2R2P 25
C44	Electrolytic	2.2	25V	CEA 2R2P 25
C45	Electrolytic	0.47	50V	CEA R47P 50

Symbol	Description			Part No.
C46	Electrolytic	0.47	50V	CEA R47P 50
C47	Ceramic	0.04	50V	CKDYF 403Z 50
C48	Ceramic	8p	50V	CCDXL 080F 50
C49	Styrol	300p	50V	CQSA 301J 50
C50	Mylar	0.01	50V	CQMA 103K 50
C51	Ceramic	0.04	50V	CKDYF 403Z 50
C52	Electrolytic	4.7	25V	CEA 4R7P 25
C53	Electrolytic	47	6V	CEA 470P 6
C54	Ceramic	220p	50V	CCDSL 221K 50
C55	Ceramic	0.01	50V	CKDYF 103Z 50
C56	Ceramic	0.01	50V	CKDYF 103Z 50
C57	Ceramic	0.005	50V	CKDYF 502Z 50
C58	Electrolytic	10	16V	CEA 100P 16
C59	Ceramic	0.04	50V	CKDYF 403Z 50
C60	Electrolytic	0.1	25V	CSSA 0R1M 25
C61	Ceramic	0.01	50V	CKDYB 103K 50
C62	Ceramic	0.01	50V	CKDYB 103K 50
C63	Electrolytic	220	16V	CEA 221P 16
C64				
VC1	Tuning capacitor			ACK-006-0
TC4	Ceramic trimmer			C43-007-A

RESISTORS

Symbol	Description			Part No.
R1	Carbon film	1M		RD%PS 105J
R2	Carbon film	1.8k		RD%VS 182J
R3	Carbon film	5.6k		RD%PS 562J
R4	Carbon film	27		RD%VS 270J
R5	Carbon film	150		RD%VS 151J
R6	Carbon film	12k		RD%PS 123J
R7	Carbon film	220k		RD%VS 224J
R8				
R9	Carbon film	22		RD%VS 220J
R10	Carbon film	150		RD%PS 151J
R11	Carbon film	4.7k		RD%VS 472J
R12	Carbon film	10k		RD%VS 103J
R13	Carbon film	1k		RD%VS 102J
R14	Carbon film	1k		RD%VS 102J
R15	Carbon film	22		RD%VS 220J
R16	Carbon film	100		RD%PS 101J
R17	Carbon film	100		RD%PS 101J
R18	Carbon film	330		RD%PS 331J
R19	Carbon film	330		RD%PS 331J
R20	Carbon film	560k		RD%PS 564J

Continued on the Next Page

Symbol	Description	Part No.
R21	Carbon film 330	RD%PS 331J
R22	Carbon film 12k	RD%PS 123J
R23	Carbon film 220k	RD%VS 224J
R24	Carbon film 8.2k	RD%PS 822J
R25	Carbon film 330	RD%PS 331J
R26	Carbon film 2.4k	RD%VS 242J
R27	Carbon film 16k	RD%PS 163J
R28	Carbon film 2.2k	RD%PS 222J
R29	Carbon film 47k	RD%PS 473J
R30	Carbon film 100k	RD%PS 104J
R31	Carbon film 5.6k	RD%PS 562J
R32	Carbon film 5.6k	RD%PS 562J
R33	Carbon film 15k	RD%VS 153J
R34		
R35		
R36		
R37	Carbon film 3.3k	RD%VS 332J
R38	Carbon film 10	RD%VS 100J
R39	Carbon film 10	RD%PS 100J
R40	Carbon film 100k	RD%PS 104J
R41	Carbon film 10	RD%PS 100J
R42	Carbon film 10	RD%PS 100J
R43	Carbon film 3.3k	RD%PS 332J
R44	Carbon film 3.3k	RD%PS 332J
R45	Carbon film 1.8k	RD%PS 182J
R46	Carbon film 1.8k	RD%PS 182J
R47	Carbon film 18k	RD%PS 183J
R48	Carbon film 18k	RD%PS 183J
R49	Carbon film 3.9k	RD%PS 392J
R50	Carbon film 3.9k	RD%PS 392J
R51	Carbon film 3.9k	RD%PS 392J
R52	Carbon film 3.9k	RD%PS 392J
R53	Carbon film 1.2k	RD%PS 122J
R54	Carbon film 1.2k	RD%PS 122J
R55	Carbon film 220k	RD%PS 224J
R56	Carbon film 220k	RD%PS 224J
R57	Carbon film 47	RD%PS 470J
R58	Carbon film 47k	RD%PS 473J
R59	Carbon film 47k	RD%PS 473J
R60	Carbon film 3.3k	RD%PS 332J
R61	Carbon film 22k	RD%PS 223J
R62	Carbon film 680	RD%PS 681J
R63	Carbon film 1k	RD%PS 102J
R64	Carbon film 2.2k	RD%PS 222J
R65	Carbon film 100	RD%PS 101J
R66	Carbon film 47	RD%PS 470J
R67	Carbon film 15k	RD%PS 153J
R68	Carbon film 10k	RD%PS 103J

POTENTIOMETERS

Symbol	Description	Part No.
VR1	Variable resistor 4.7k-B, Semi-fixed	C92-055-0
VR2	Variable resistor 330k-B, Semi-fixed	ACP-042-0
VR3	Variable resistor 50k-B, Semi-fixed	ACP-043-0
VR4	Variable resistor 47k-B, Semi-fixed	C92-048-0
VR5	Variable resistor 2.2k-B, Semi-fixed	ACP-001-0

SEMICONDUCTORS

Symbol	Description	Part No.
Q1	FET 3SK45-B	
Q2	FET 3SK45-B	
Q3	Transistor 2SC717	
Q4	Transistor 2SC461-B	
Q5	IC HA1201	
Q6	IC HA1137	
Q7	IC HA1138	
Q8	IC HA1156	
Q9		
Q10	Transistor 2SC945-Q, R or S	
Q11	Transistor 2SA763P-6 or 5 (2SA725-F or G)	
Q12	Transistor 2SA763P-6 or 5 (2SA725-F or G)	
Q13	Transistor 2SC945-Q, R or S	
Q14	Transistor 2SC945-Q, R or S	
D1	Diode 1S2076	
D2	Diode 1S2076	

COILS, FILTERS AND TRANSFORMERS

Symbol	Description	Part No.
T1	FM antenna coil	ATC-021-0
T2	FM RF coil	ATC-015-0
T3	FM RF coil	ATC-016-0
T4	FM OSC coil	ATC-022-0
T5	FM matching transformer	ATE-008-0
T6	FM IF transformer	T73-035-A
T7	AM RF coil	ATB-014-0
T8	AM OSC coil	ATB-013-0
F1	FM ceramic filter	ATF-013-B
F2	FM ceramic filter	ATF-013-B
F3	FM ceramic filter	ATF-013-B
F4	AM ceramic filter	ATF-009-0
F5	Low pass filter	ATF-019-0
L1	Choke coil	ATH-007-0
L2	RF choke coil	T24-028-A
L3	RF choke coil	T24-028-A
L4	RF choke coil	T24-028-A
L5	RF choke coil	T24-028-A

12. 3 MUTING CIRCUIT ASSEMBLY (AWM-063-0)

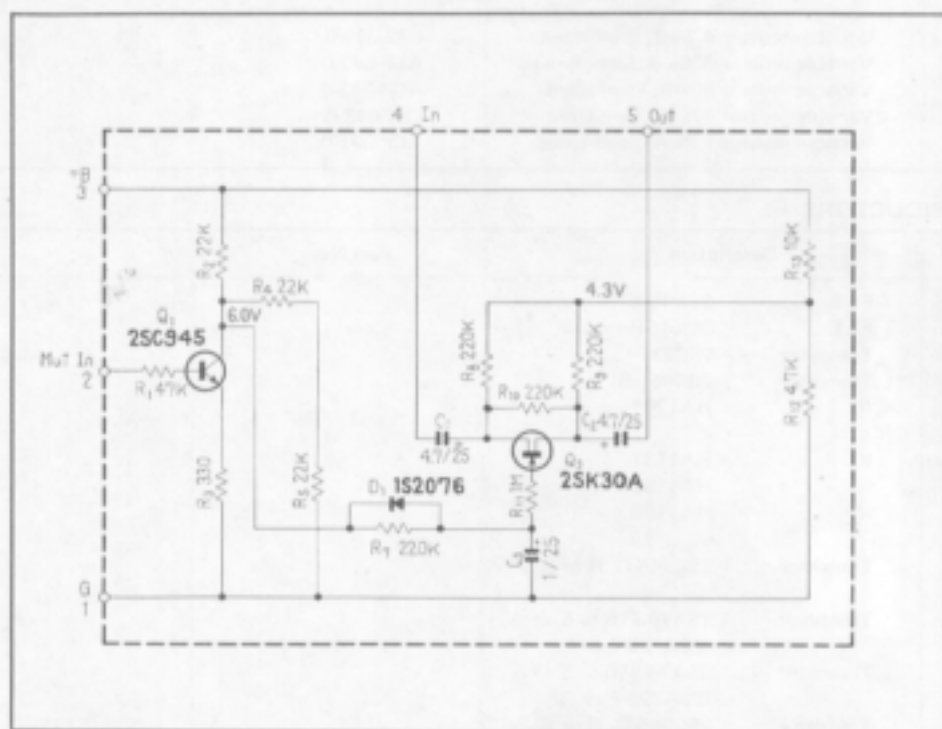

Foil Side

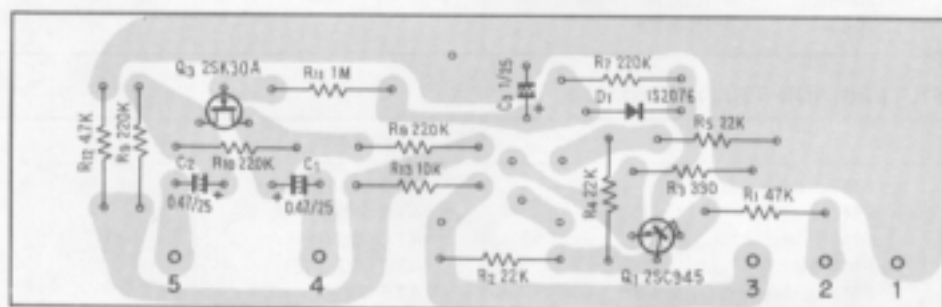

2SK30A



2SC945



Parts List of Muting Circuit Assembly (AWM-063-0)

CAPACITORS

Symbol	Description	Part No.
C1	Electrolytic 4.7 25V	CEA 4R7P 25
C2	Electrolytic 4.7 25V	CEA 4R7P 25
C3	Electrolytic 1 25V	CSSA 010M 25

RESISTORS

Symbol	Description	Part No.
R1	Carbon film 47k	RD%PS 473J
R2	Carbon film 22k	RD%PS 223J
R3	Carbon film 330	RD%PS 331J
R4	Carbon film 22k	RD%PS 223J
R5	Carbon film 22k	RD%PS 223J
R6		
R7	Carbon film 220k	RD%PS 224J
R8	Carbon film 220k	RD%PS 224J
R9	Carbon film 220k	RD%PS 224J
R10	Carbon film 220k	RD%PS 224J
R11	Carbon film 1M	RD%PS 105J
R12	Carbon film 4.7k	RD%PS 472J
R13	Carbon film 10k	RD%PS 103J

SEMICONDUCTORS

Symbol	Description	Part No.
Q1	Transistor 2SC945-Q	
Q2		
Q3	FET 2SK30A-Y	
D1	Diode 1S2076	

12. 4 EQUALIZER AMPLIFIER ASSEMBLY (AWF-013-0)

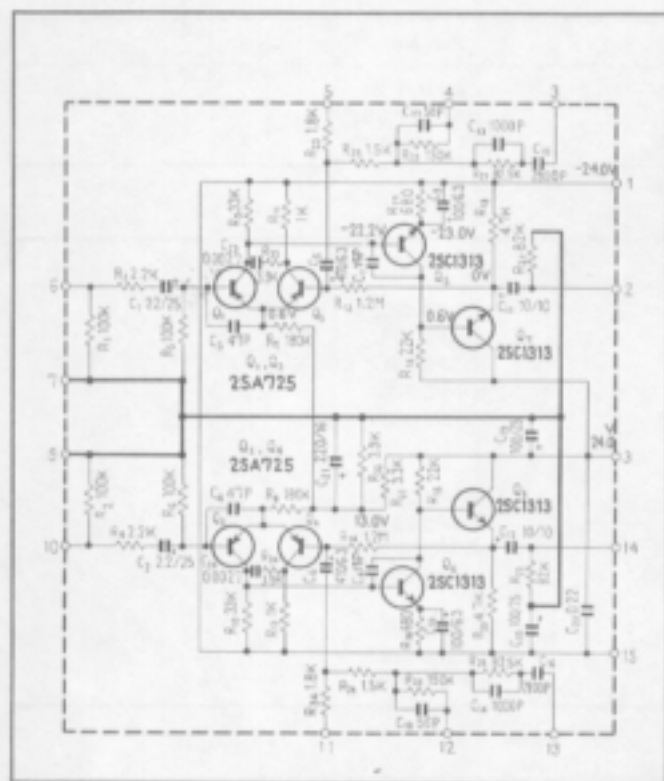

25A725
25C1313



25A640
25A763P
25C1222



25C1345



Foil Side

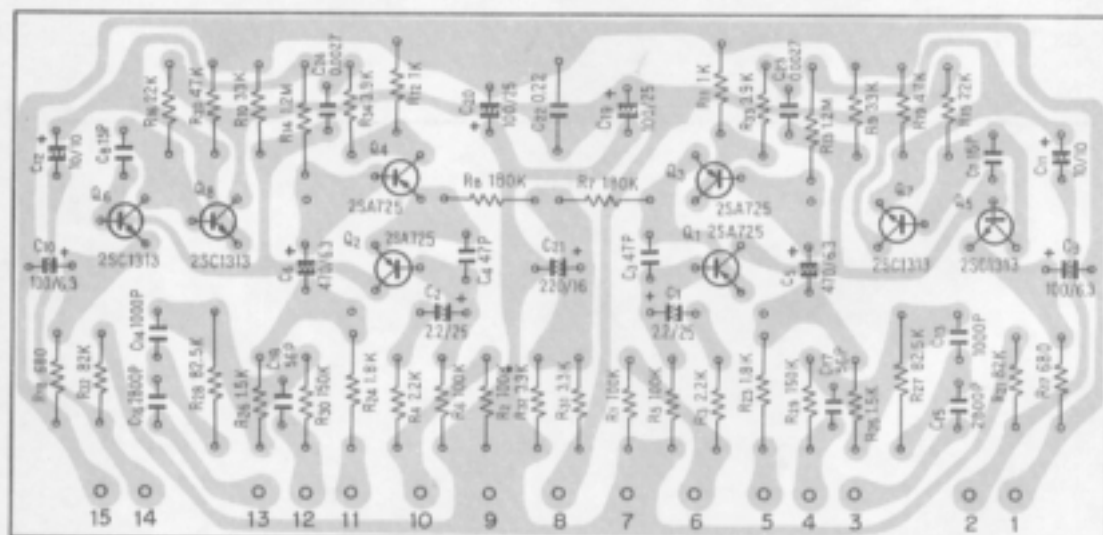

Parts List of Equalizer Amplifier Assembly (AWF-013-0)

CAPACITORS

Symbol	Description	Part No.
C1	Electrolytic 2.2 25V	CSSA 2R2M 25
C2	Electrolytic 2.2 25V	CSSA 2R2M 25
C3	Ceramic 47p 50V	CCDSL 470K 50
C4	Ceramic 47p 50V	CCDSL 470K 50
C5	Electrolytic 470 6V	CEANL 471P 6
C6	Electrolytic 470 6V	CEANL 471P 6
C7	Ceramic 15p 50V	CCDSL 150K 50
C8	Ceramic 15p 50V	CCDSL 150K 50
C9	Electrolytic 100 6V	CEANL 101P 6
C10	Electrolytic 100 6V	CEANL 101P 6
C11	Electrolytic 10 10V	CEANL 100P 10
C12	Electrolytic 10 10V	CEANL 100P 10
C13	Styrol 0.001 50V	CQSA 102G 50
C14	Styrol 0.001 50V	CQSA 102G 50
C15	Styrol 0.0028 50V	CQSA 282G 50
C16	Styrol 0.0028 50V	CQSA 282G 50
C17	Ceramic 56p 50V	CCDSL 560K 50
C18	Ceramic 56p 50V	CCDSL 560K 50
C19	Electrolytic 100 25V	CEANL 101P 25
C20	Electrolytic 100 25V	CEANL 101P 25
C21	Electrolytic 220 16V	CEANL 221P 16
C22	Mylar 0.22 50V	CQMA 224K 50
C23	Mylar 0.0027 50V	CQMA 272K 50
C24	Mylar 0.0027 50V	CQMA 272K 50

RESISTORS

Symbol	Description	Part No.
R1	Carbon film 100k	RD%PM 104J
R2	Carbon film 100k	RD%PM 104J
R3	Carbon film 2.2k	RD%PM 222J
R4	Carbon film 2.2k	RD%PM 222J
R5	Carbon film 100k	RD%PM 104J
R6	Carbon film 100k	RD%PM 104J
R7	Carbon film 180k	RD%PM 184JNL
R8	Carbon film 180k	RD%PM 184JNL
R9	Carbon film 33k	RD%PM 333J
R10	Carbon film 33k	RD%PM 333J
R11	Carbon film 1k	RD%PM 102J
R12	Carbon film 1k	RD%PM 102J
R13	Carbon film 1.2M	RD%PS 125J
R14	Carbon film 1.2M	RD%PS 125J
R15	Carbon film 22k	RD%PM 223J
R16	Carbon film 22k	RD%PM 223J
R17	Carbon film 680	RD%PM 681J
R18	Carbon film 680	RD%PM 681J
R19	Carbon film 4.7k	RD%PM 472J
R20	Carbon film 4.7k	RD%PM 472J

Continued on the Next Page

41

Symbol	Description	Part No.
R21	Carbon film 82k	RD%PM 823J
R22	Carbon film 82k	RD%PM 823J
R23	Carbon film 1.8k	RD%PS 182J
R24	Carbon film 1.8k	RD%PS 182J
R25	Carbon film 1.5k	RD%PM 152J
R26	Carbon film 1.5k	RD%PM 152J
R27	Metal film 82.5k 1/2W	RN%SR 8252F
R28	Metal film 82.5k 1/2W	RN%SR 8252F
R29	Carbon film 150k	RD%PM 154J
R30	Carbon film 150k	RD%PM 154J
R31	Carbon film 3.3k	RD%PM 332J
R32	Carbon film 3.9k	RD%PM 392J
R33	Carbon film 3.9k	RD%PM 392J
R34	Carbon film 3.9k	RD%PM 392J

SEMICONDUCTORS

Symbol	Description	Part No.
Q1	Transistor 2SA725-G or F (2SA763P-5 or 6) (2SA640-K, L or M)	
Q2	Transistor 2A725-G or F (2SA763P-5 or 6) (2SA640-K, L or M)	
Q3	Transistor 2A725-G or F (2SA763P-5 or 6) (2SA640-K, L or M)	
Q4	Transistor 2A725-G or F (2SA763P-5 or 6) (2SA640-K, L or M)	
Q5	Transistor 2SC1313-G or F (2SC1345-E or D) (2SC1222-F, E or U)	
Q6	Transistor 2SC1313-G or F (2SC1345-E or D) (2SC1222-F, E or U)	
Q7	Transistor 2SC1313-G or F (2SC1345-E or D) (2SC1222-F, E or U)	
Q8	Transistor 2SC1313-G or F (2SC1345-E or D) (2SC1222-F, E or U)	

12. 5 CONTROL AMPLIFIER ASSEMBLY (AWG-027-0)

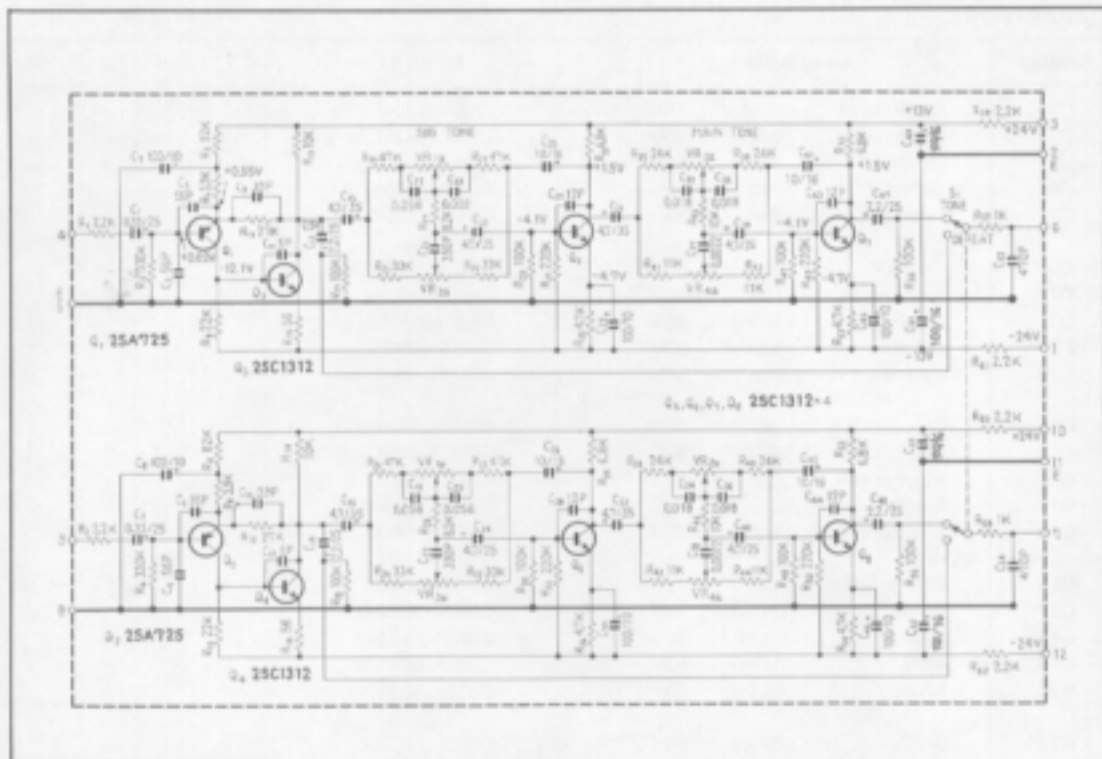

Foil Side

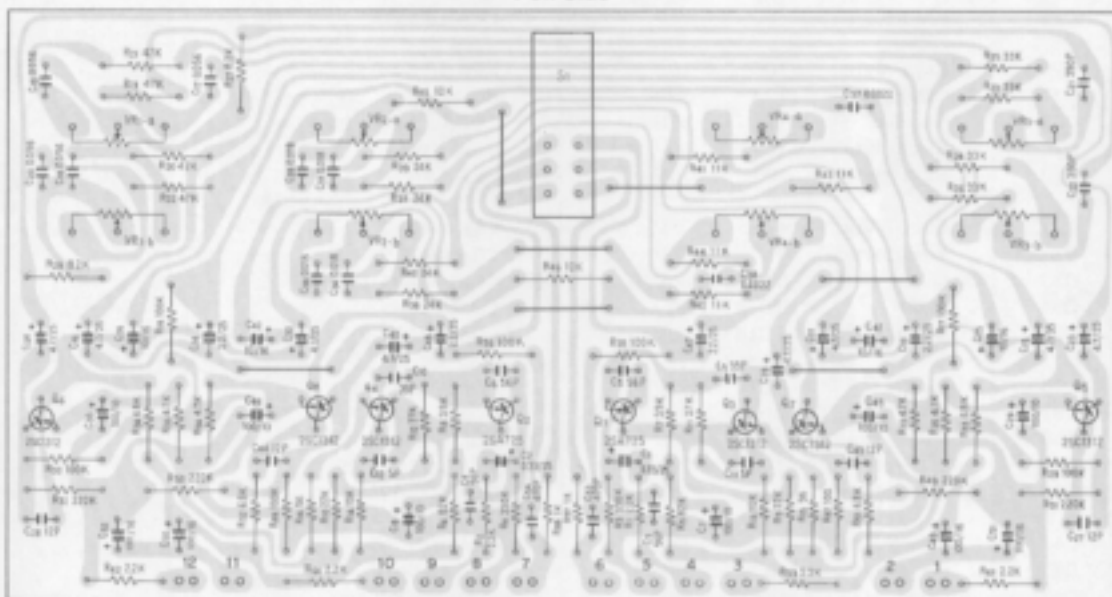

2SA725
2SC1312

2SA763P
2SA640
2SC900

2SC1344

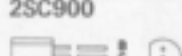

Parts List of Control Amplifier Assembly (AWG-027-0)

CAPACITORS

Symbol	Description			Part No.
C1	Electrolytic	0.33	25V	CSSA R33M 25
C2	Electrolytic	0.33	25V	CSSA R33M 25
C3	Ceramic	56p	50V	CCDSL 560K 50
C4	Ceramic	56p	50V	CCDSL 560K 50
C5	Ceramic	56p	50V	CCDSL 560K 50
C6	Ceramic	56p	50V	CCDSL 560K 50
C7	Electrolytic	100	10V	CEA 101P 10
C8	Electrolytic	100	10V	CEA 101P 10
C9	Ceramic	39p	50V	CCDSL 390K 50
C10	Ceramic	39p	50V	CCDSL 390K 50
C11	Ceramic	5p	50V	CCDSL 050D 50
C12	Ceramic	5p	50V	CCDSL 050D 50
C13	Electrolytic	2.2	25V	CSSA 2R2M 25
C14	Electrolytic	2.2	25V	CSSA 2R2M 25
C15	Electrolytic	4.7	35V	CEA 4R7P 35
C16	Electrolytic	4.7	35V	CEA 4R7P 35
C17	Mylar	0.056	50V	QOMA 563J 50
C18	Mylar	0.056	50V	QOMA 563J 50
C19	Mylar	0.056	50V	QOMA 563J 50
C20	Mylar	0.056	50V	QOMA 563J 50
C21	Styrol	390p	50V	QOSA 391J 50
C22	Styrol	390p	50V	QOSA 391J 50
C23	Electrolytic	4.7	25V	CEANL 4R7P 25
C24	Electrolytic	4.7	25V	CEANL 4R7P 25
C25	Electrolytic	10	16V	CEA 100P 16
C26	Electrolytic	10	16V	CEA 100P 16
C27	Ceramic	12p	50V	CCDSL 120K 50
C28	Ceramic	12p	50V	CCDSL 120K 50
C29	Electrolytic	100	10V	CEA 101P 10
C30	Electrolytic	100	10V	CEA 101P 10
C31	Electrolytic	4.7	35V	CEA 4R7P 35
C32	Electrolytic	4.7	35V	CEA 4R7P 35
C33	Mylar	0.018	50V	QOMA 183J 50
C34	Mylar	0.018	50V	QOMA 183J 50
C35	Mylar	0.018	50V	QOMA 183J 50
C36	Mylar	0.018	50V	QOMA 183J 50
C37	Mylar	0.0022	50V	QOMA 222J 50
C38	Mylar	0.0022	50V	QOMA 222J 50
C39	Electrolytic	4.7	25V	CEANL 4R7P 25
C40	Electrolytic	4.7	25V	CEANL 4R7P 25
C41	Electrolytic	10	16V	CEA 100P 16
C42	Electrolytic	10	16V	CEA 100P 16
C43	Ceramic	12p	50V	CCDSL 120K 50
C44	Ceramic	12p	50V	CCDSL 120K 50
C45	Electrolytic	100	10V	CEA 101P 10

Symbol	Description	Part No.
C46	Electrolytic 100 10V	CEA 101P 10
C47	Electrolytic 2.2 25V	CSSA 2R2M 25
C48	Electrolytic 2.2 25V	CSSA 2R2M 25
C49	Electrolytic 100 16V	CEA 101P 16
C50	Electrolytic 100 16V	CEA 101P 16
C51	Electrolytic 100 16V	CEA 101P 16
C52	Electrolytic 100 16V	CEA 101P 16
C53	Ceramic 470p 50V	CKDYB 471K 50
C54	Ceramic 470p 50V	CKDYB 471K 50

RESISTORS

Symbol	Description	Part No.
R1	Carbon film 2.2k	RD%PS 222J
R2	Carbon film 2.2k	RD%PS 222J
R3	Carbon film 330k	RD%PS 334J
R4	Carbon film 330k	RD%PS 334J
R5	Carbon film 82k	RD%PS 823J
R6	Carbon film 82k	RD%PS 823J
R7	Carbon film 3.9k	RD%PS 392J
R8	Carbon film 3.9k	RD%PS 392J
R9	Carbon film 22k	RD%PS 223J
R10	Carbon film 22k	RD%PS 223J
R11	Carbon film 27k	RD%PS 273J
R12	Carbon film 27k	RD%PS 273J
R13	Carbon film 10k	RD%PS 103J
R14	Carbon film 10k	RD%PS 103J
R15	Carbon film 56	RD%PS 560J
R16	Carbon film 56	RD%PS 560J
R17	Carbon film 100k	RD%PS 104J
R18	Carbon film 100k	RD%PS 104J
R19	Carbon film 47k	RD%PS 473J
R20	Carbon film 47k	RD%PS 473J
R21	Carbon film 47k	RD%PS 473J
R22	Carbon film 47k	RD%PS 473J
R23	Carbon film 33k	RD%PS 333J
R24	Carbon film 33k	RD%PS 333J
R25	Carbon film 33k	RD%PS 333J
R26	Carbon film 33k	RD%PS 333J
R27	Carbon film 8.2k	RD%PS 822J
R28	Carbon film 8.2k	RD%PS 822J
R29	Carbon film 100k	RD%PS 104J
R30	Carbon film 100k	RD%PS 104J
R31	Carbon film 220k	RD%PS 224J
R32	Carbon film 220k	RD%PS 224J
R33	Carbon film 6.8k	RD%PS 682J
R34	Carbon film 6.8k	RD%PS 682J
R35	Carbon film 4.7k	RD%PS 472J

Continued on the Next Page

Symbol	Description	Part No.
R36	Carbon film 4.7k	RD%PS 472J
R37	Carbon film 24k	RD%PS 243J
R38	Carbon film 24k	RD%PS 243J
R39	Carbon film 24k	RD%PS 243J
R40	Carbon film 24k	RD%PS 243J
R41	Carbon film 11k	RD%PS 113J
R42	Carbon film 11k	RD%PS 113J
R43	Carbon film 11k	RD%PS 113J
R44	Carbon film 11k	RD%PS 113J
R45	Carbon film 10k	RD%PS 103J
R46	Carbon film 10k	RD%PS 103J
R47	Carbon film 100k	RD%PS 104J
R48	Carbon film 100k	RD%PS 104J
R49	Carbon film 220k	RD%PS 224J
R50	Carbon film 220k	RD%PS 224J
R51	Carbon film 6.8k	RD%PS 682J
R52	Carbon film 6.8k	RD%PS 682J
R53	Carbon film 4.7k	RD%PS 472J
R54	Carbon film 4.7k	RD%PS 472J
R55	Carbon film 100k	RD%PS 104J
R56	Carbon film 100k	RD%PS 104J
R57	Carbon film 1k	RD%PS 102J
R58	Carbon film 1k	RD%PS 102J
R59	Carbon film 2.2k	RD%PS 222J
R60	Carbon film 2.2k	RD%PS 222J
R61	Carbon film 2.2k	RD%PS 222J
R62	Carbon film 2.2k	RD%PS 222J

POTENTIOMETERS

Symbol	Description	Part No.
VR1	Variable resistor (Bass-sub)	ACV-132-0
VR2	Variable resistor (Bass-main)	ACV-130-0
VR3	Variable resistor (Treble-sub)	ACV-133-0
VR4	Variable resistor (Treble-main)	ACV-131-0

SEMICONDUCTORS

Symbol	Description	Part No.
Q1	Transistor 2SA725-F or G (2SA763P-5 or 6) (2SA640-K or L)	
Q2	Transistor 2SA725-F or G (2SA763P-5 or 6) (2SA640-K or L)	
Q3	Transistor 2SC1312-G or H (2SC1344-D or E) (2SC900-E or F)	
Q4	Transistor 2SC1312-G or H (2SC1344-D or E) (2SC900-E or F)	
Q5	Transistor 2SC1312-G or H (2SC1344-D or E) (2SC900-E or F)	

Symbol	Description	Part No.	
Q6	Transistor 2SC1312-G or H (2SC1344-D or E) (2SC900-E or F)		
Q7	Transistor 2SC1312-G or H (2SC1344-D or E) (2SC900-E or F)		
Q8	Transistor 2SC1312-G or H (2SC1344-D or E) (2SC900-E or F)		

SWITCH

Symbol	Description	Part No.	
S1	Lever switch (Tone)	ASK-070-0	

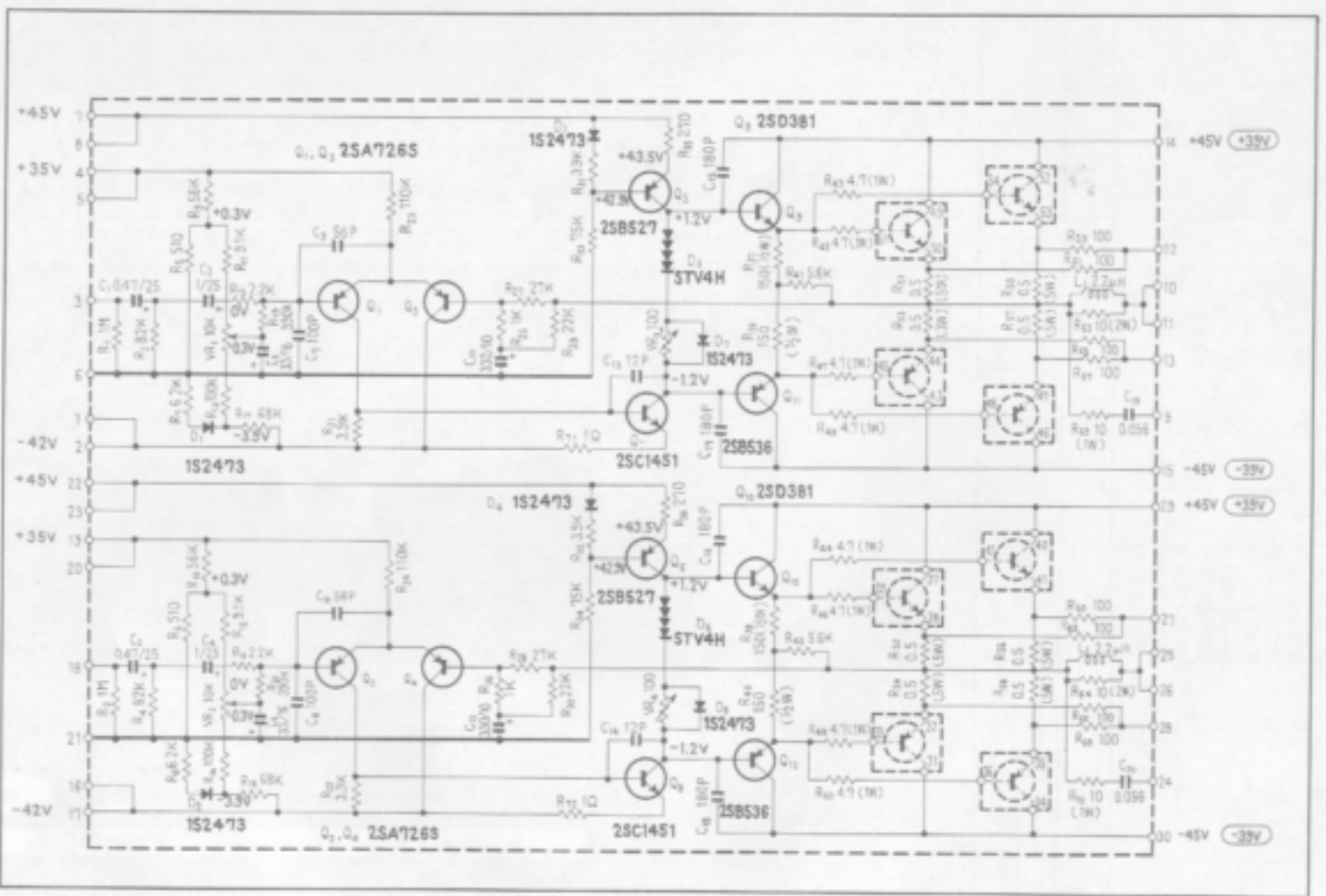

2SA726S



2SB527



2SC1451



2SB536

2SD381



Foil Side

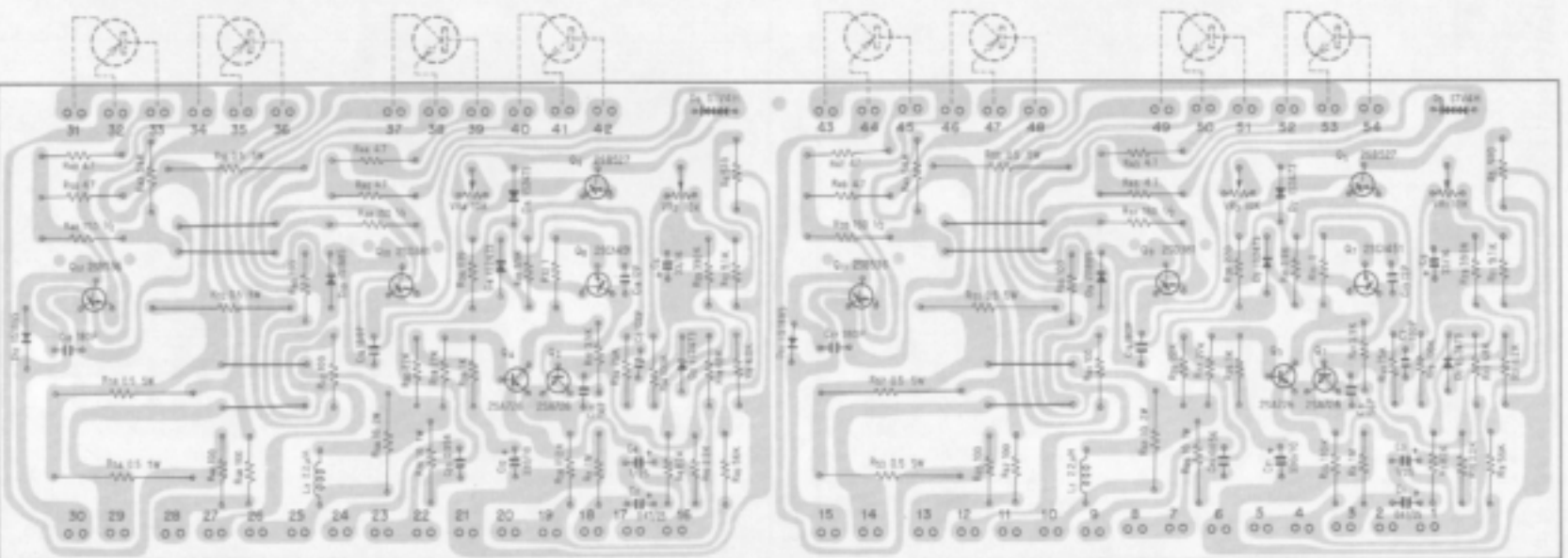

Parts List of Power Amplifier Assembly (AWH-030-0)

CAPACITORS

Symbol	Description			Part No.
C1	Electrolytic	0.47	25V	CSSA R47P 25
C2	Electrolytic	0.47	25V	CSSA R47P 25
C3	Electrolytic	1	25V	CSSA 010P 25
C4	Electrolytic	1	25V	CSSA 010P 25
C5	Electrolytic	33	16V	CEA 330P 16
C6	Electrolytic	33	16V	CEA 330P 16
C7	Ceramic	100p	50V	CCDSL 101K 50
C8	Ceramic	100p	50V	CCDSL 101K 50
C9	Ceramic	56p	50V	CCDSL 560K 50
C10	Ceramic	56p	50V	CCDSL 560K 50
C11	Electrolytic	330	10V	CEA 331P 10
C12	Electrolytic	330	10V	CEA 331P 10
C13	Ceramic	12p	500V	CCDSL 120K 500
C14	Ceramic	12p	500V	CCDSL 120K 500
C15	Ceramic	180p	500V	CCDSL 181K 500
C16	Ceramic	180p	500V	CCDSL 181K 500
C17	Ceramic	180p	500V	CCDSL 181K 500
C18	Ceramic	180p	500V	CCDSL 181K 500
C19	Mylar	0.056	50V	QOMA 563M 50
C20	Mylar	0.056	50V	QOMA 563M 50

RESISTORS

Symbol	Description			Part No.
R1	Carbon film	1M		RD%PS 105J
R2	Carbon film	1M		RD%PS 105J
R3	Carbon film	82k		RD%PS 823J
R4	Carbon film	82k		RD%PS 823J
R5	Carbon film	510		RD%PS 511J
R6	Carbon film	510		RD%PS 511J
R7	Carbon film	6.2k		RD%PS 622J
R8	Carbon film	6.2k		RD%PS 622J
R9	Carbon film	56k		RD%PS 563J
R10	Carbon film	56k		RD%PS 563J
R11	Carbon film	9.1k		RD%PS 912J
R12	Carbon film	9.1k		RD%PS 912J
R13	Carbon film	100k		RD%PS 104J
R14	Carbon film	100k		RD%PS 104J
R15	Carbon film	2.2k		RD%PS 222J
R16	Carbon film	2.2k		RD%PS 222J
R17	Carbon film	68k		RD%PS 683J
R18	Carbon film	68k		RD%PS 683J
R19	Carbon film	390k		RD%PS 394J
R20	Carbon film	390k		RD%PS 394J
R21	Carbon film	3.9k		RD%PS 392J
R22	Carbon film	3.9k		RD%PS 392J
R23	Carbon film	110k		RD%PS 114J
R24	Carbon film	110k		RD%PS 114J
R25	Carbon film	1k		RD%PS 102J

Symbol	Description	Part No.
R26	Carbon film 1k	RD%PS 102J
R27	Carbon film 27k	RD%PS 273J
R28	Carbon film 27k	RD%PS 273J
R29	Carbon film 22k	RD%PS 223J
R30	Carbon film 22k	RD%PS 223J
R31	Carbon film 3.9k	RD%PS 392J
R32	Carbon film 3.9k	RD%PS 392J
R33	Carbon film 75k	RD%PS 753J
R34	Carbon film 75k	RD%PS 753J
R35	Carbon film 270	RD%PS 271J
R36	Carbon film 270	RD%PS 271J
R37	Carbon film 150 1/2W	RD%PS 151J
R38	Carbon film 150 1/2W	RD%PS 151J
R39	Carbon film 150 1/2W	RD%PS 151J
R40	Carbon film 150 1/2W	RD%PS 151J
R41	Carbon film 5.6k	RD%PS 562J
R42	Carbon film 5.6k	RD%PS 562J
R43	Metal film 4.7 1W	RN1H 4R7K
R44	Metal film 4.7 1W	RN1H 4R7K
R45	Metal film 4.7 1W	RN1H 4R7K
R46	Metal film 4.7 1W	RN1H 4R7K
R47	Metal film 4.7 1W	RN1H 4R7K
R48	Metal film 4.7 1W	RN1H 4R7K
R49	Metal film 4.7 1W	RN1H 4R7K
R50	Metal film 4.7 1W	RN1H 4R7K
R51	Wire wound 0.5 5W	RT5B 0R5K
R52	Wire wound 0.5 5W	RT5B 0R5K
R53	Wire wound 0.5 5W	RT5B 0R5K
R54	Wire wound 0.5 5W	RT5B 0R5K
R55	Wire wound 0.5 5W	RT5B 0R5K
R56	Wire wound 0.5 5W	RT5B 0R5K
R57	Wire wound 0.5 5W	RT5B 0R5K
R58	Wire wound 0.5 5W	RT5B 0R5K
R59	Carbon film 100	RD%PS 101J
R60	Carbon film 100	RD%PS 101J
R61	Carbon film 100	RD%PS 101J
R62	Carbon film 100	RD%PS 101J
R63	Metal oxide 10 2W	RS2P 100J
R64	Metal oxide 10 2W	RS2P 100J
R65	Carbon film 100	RD%PS 101J
R66	Carbon film 100	RD%PS 101J
R67	Carbon film 100	RD%PS 101J
R68	Carbon film 100	RD%PS 101J
R69	Metal oxide 10 1W	RS1P 100J
R70	Metal oxide 10 1W	RS1P 100J
R71	Carbon film 1	RD%PS 010J
R72	Carbon film 1	RD%PS 010J

Continued on the Next Page

POTENTIOMETERS

Symbol	Description	Part No.
VR1	Variable resistor 10k-B, semi-fixed	ACP-029-0
VR2	Variable resistor 10k-B, semi-fixed	ACP-029-0
VR3	Variable resistor 100-B, semi-fixed	ACP-019-A
VR4	Variable resistor 100-B, semi-fixed	ACP-019-A

SEMICONDUCTORS

Symbol	Description	Part No.
Q1	Transistor 2SA726S-F or G	
Q2	Transistor 2SA726S-F or G	
Q3	Transistor 2SA726S-F or G	
Q4	Transistor 2SA726S-F or G	
Q5	Transistor 2SB527-C or D	
Q6	Transistor 2SB527-C or D	
Q7	Transistor 2SC1451-V or B	
Q8	Transistor 2SC1451-V or B	
Q9	Transistor 2SD381-M or L	
Q10	Transistor 2SD381-M or L	
Q11	Transistor 2SB536-M or L	
Q12	Transistor 2SB536-M or L	
D1	Diode 1S2473	
D2	Diode 1S2473	
D3	Diode 1S2473	
D4	Diode 1S2473	
D5	Varistor STV4H	
D6	Varistor STV4H	
D7	Diode 1S2473	
D8	Diode 1S2473	

COILS

Symbol	Description	Part No.
L1	AF choke coil	T63-009-0
L2	AF choke coil	T63-009-0

OTHERS

Symbol	Description	Part No.
	Heat sink	ANH-203-0

12. 7 PROTECTION CIRCUIT ASSEMBLY (AWM-062-0)

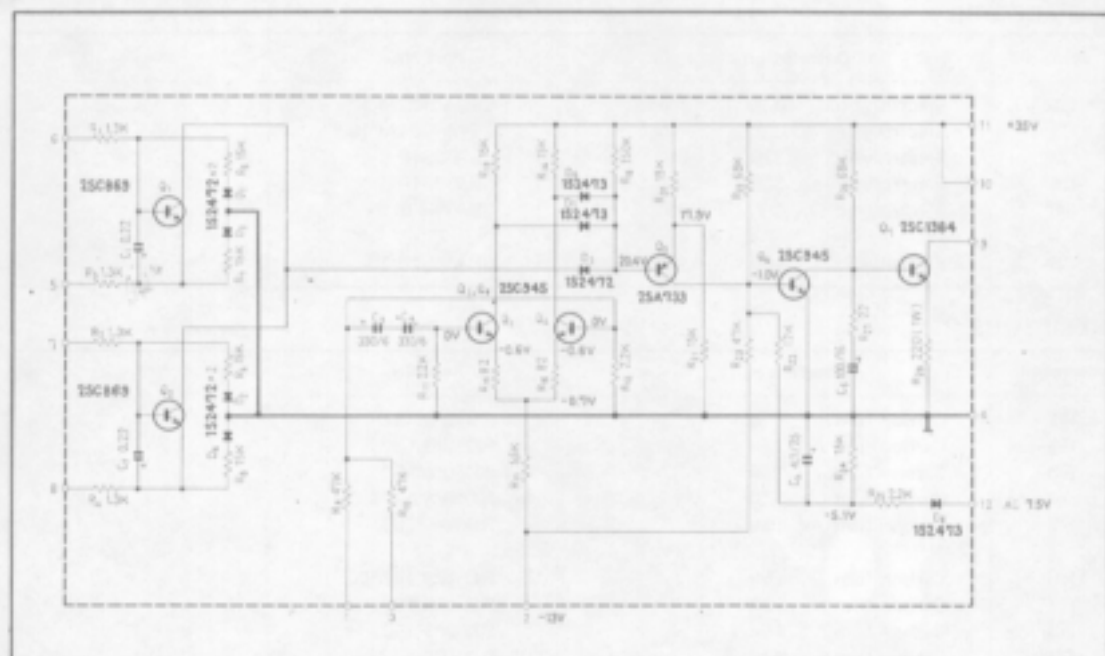

Foil Side

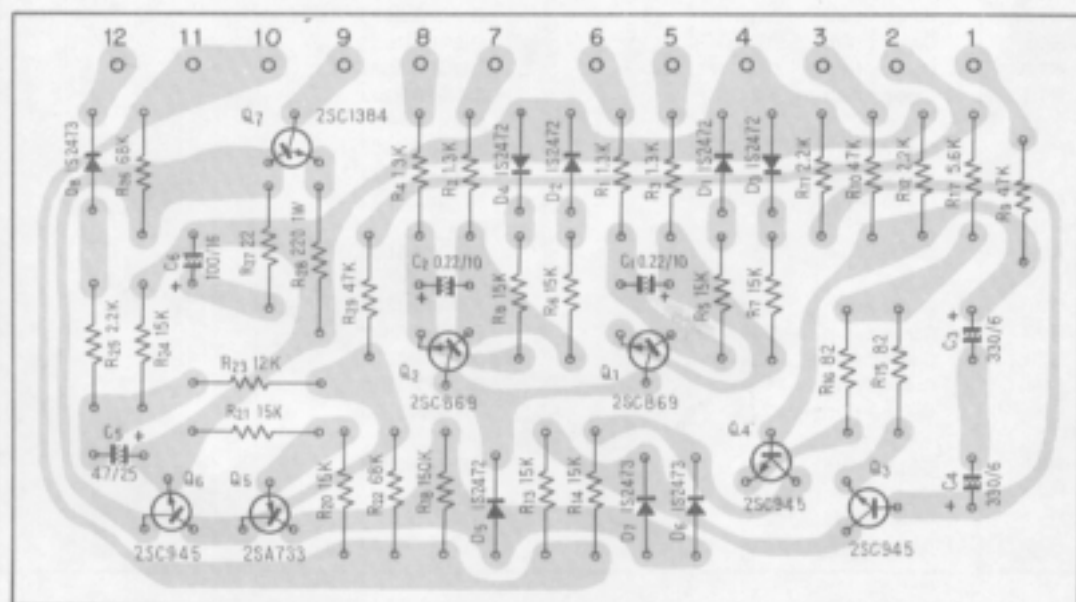

2SC869



2SC857



2SC1515



2SA733
2SC945

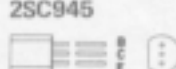

2SC1384



Parts List of Protection Circuit Assembly (AWM-062-0)

CAPACITORS

Symbol	Description	Part No.
C1	Electrolytic 0.22 10V	CSSA R22M 10
C2	Electrolytic 0.22 10V	CSSA R22M 10
C3	Electrolytic 330 6V	CEA 331P 6
C4	Electrolytic 330 6V	CEA 331P 6
C5	Electrolytic 4.7 25V	CEA 4R7P 25
C6	Electrolytic 100 16V	CEA 101P 16

RESISTORS

Symbol	Description	Part No.
R1	Carbon film 1.3k	RD%PS 132J
R2	Carbon film 1.3k	RD%PS 132J
R3	Carbon film 1.3k	RD%PS 132J
R4	Carbon film 1.3k	RD%PS 132J
R5	Carbon film 15k	RD%PS 153J
R6	Carbon film 15k	RD%PS 153J
R7	Carbon film 15k	RD%PS 153J
R8	Carbon film 15k	RD%PS 153J
R9	Carbon film 47k	RD%PS 473J
R10	Carbon film 47k	RD%PS 473J
R11	Carbon film 2.2k	RD%PS 222J
R12	Carbon film 2.2k	RD%PS 222J
R13	Carbon film 15k	RD%PS 153J
R14	Carbon film 15k	RD%PS 153J
R15	Carbon film 82	RD%PS 820J
R16	Carbon film 82	RD%PS 820J
R17	Carbon film 5.6k	RD%PS 562J
R18	Carbon film 150k	RD%PS 154J
R19		
R20	Carbon film 15k	RD%PS 153J
R21	Carbon film 15k	RD%PS 153J
R22	Carbon film 68k	RD%PS 683J
R23	Carbon film 12k	RD%PS 123J
R24	Carbon film 15k	RD%PS 153J
R25	Carbon film 2.2k	RD%PS 222J
R26	Carbon film 68k	RD%PS 683J
R27	Carbon film 22	RD%PS 220J
R28	Metal oxide 220 1W	RS1P 221J
R29	Carbon film 47k	RD%PS 473J

SEMICONDUCTORS

Symbol	Description	Part No.	
Q1	Transistor	2SC869-C, B or D (2SC857-K or A) (2SC1515-K)	
Q2	Transistor	2SC869-C, B or D (2SC857-K or A) (2SC1515-K)	
Q3	Transistor	2SC945-Q or R	
Q4	Transistor	2SC945-Q or R	
Q5	Transistor	2SA733-Q or R	
Q6	Transistor	2SC945-Q or R	
Q7	Transistor	2SC1384-R or Q	
D1	Diode	1S2472	
D2	Diode	1S2472	
D3	Diode	1S2472	
D4	Diode	1S2472	
D5	Diode	1S2472	
D6	Diode	1S2473	
D7	Diode	1S2473	
D8	Diode	1S2473	

12. 8 POWER SUPPLY CIRCUIT ASSEMBLY (AWR-052-0)

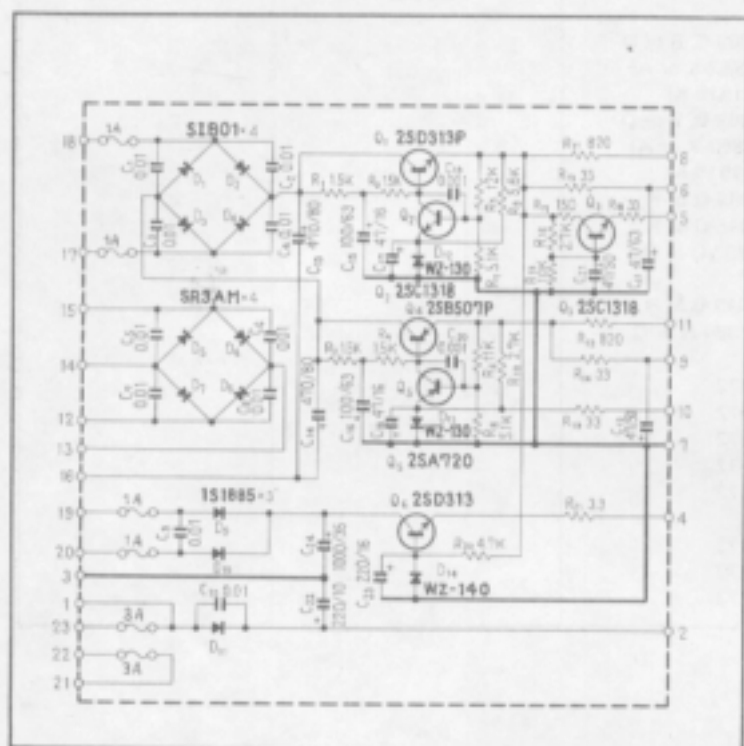

2SD313
2SD313P
2SB507P



2SA720
2SC1318



Foil Side

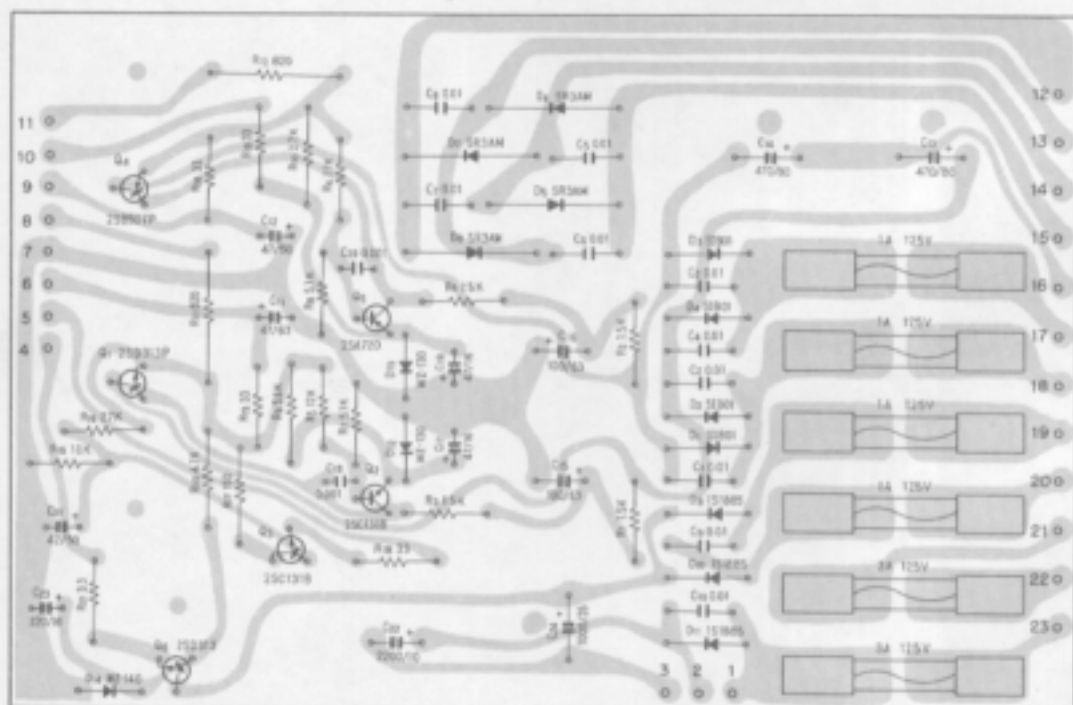

Parts List of Power Supply Circuit Assembly (AWR-052-0)

CAPACITORS

Symbol	Description			Part No.
C1	Ceramic	0.01	150V	ACG-004-0
C2	Ceramic	0.01	150V	ACG-004-0
C3	Ceramic	0.01	150V	ACG-004-0
C4	Ceramic	0.01	150V	ACG-004-0
C5	Ceramic	0.01	150V	ACG-004-0
C6	Ceramic	0.01	150V	ACG-004-0
C7	Ceramic	0.01	150V	ACG-004-0
C8	Ceramic	0.01	150V	ACG-004-0
C9	Ceramic	0.01	150V	ACG-004-0
C10	Ceramic	0.01	150V	ACG-004-0
C11	Electrolytic	47	63V	CEA 470P 63
C12	Electrolytic	47	50V	CEA 470P 50
C13	Electrolytic	470	80V	ACH-038-0
C14	Electrolytic	470	80V	ACH-038-0
C15	Electrolytic	100	63V	CEA 101P 63
C16	Electrolytic	100	63V	CEA 101P 63
C17	Electrolytic	47	16V	CEA 470P 16
C18	Electrolytic	47	16V	CEA 470P 16
C19	Ceramic	0.001	50V	CKDYF 102Z 50
C20	Ceramic	0.001	50V	CKDYF 102Z 50
C21	Electrolytic	47	50V	CEA 470P 50
C22	Electrolytic	2,200	10V	CEA 222P 10
C23	Electrolytic	220	16V	CEA 221P 16
C24	Electrolytic	1,000	35V	ACH-039-0

RESISTORS

Symbol	Description			Part No.
R1	Carbon film	1.5k		RD%PS 152J
R2	Carbon film	1.5k		RD%PS 152J
R3	Carbon film	1.5k		RD%PS 152J
R4	Carbon film	1.5k		RD%PS 152J
R5	Carbon film	12k		RD%PS 123J
R6	Carbon film	11k		RD%PS 113J
R7	Carbon film	5.1k		RD%PS 512J
R8	Carbon film	5.1k		RD%PS 512J
R9	Carbon film	5.6k	1/2W	RD%PS 562J
R10	Metal oxide	2.7k	1W	RS1P 272J
R11	Metal oxide	820	2W	RS2P 821J
R12	Metal oxide	820	2W	RS2P 821J
R13	Carbon film	33		RD%PS 330J
R14	Carbon film	33		RD%PS 330J
R15	Carbon film	10k		RD%PS 103J
R16	Carbon film	2.7k		RD%PS 272J
R17	Carbon film	150	1/2W	RD%PS 151J
R18	Carbon film	33		RD%PS 330J
R19	Carbon film	33		RD%PS 330J
R20	Carbon film	4.7k	1/2W	RD%PS 472J
R21	Carbon film	3.3		RD%PS 3R3J

Continued on the Next Page

57

SEMICONDUCTORS

Symbol	Description	Part No.
Q1	Transistor 2SD313P-E or D	
Q2	Transistor 2SC1318-Q or R	
Q3	Transistor 2SC1318-Q or R	
Q4	Transistor 2SB507P-E or D	
Q5	Transistor 2SA720-Q or R	
Q6	Transistor 2SD313-E or D	
D1	Diode S1B01-04	
D2	Diode S1B01-04	
D3	Diode S1B01-04	
D4	Diode S1B01-04	
D5	Diode SR3AM-8	
D6	Diode SR3AM-8	
D7	Diode SR3AM-8	
D8	Diode SR3AM-8	
D9	Diode 1S1885	
D10	Diode (S1B01-01) 1S1885 (S1B01-01)	
D11	Diode 1S1885 (S1B01-01)	
D12	Zener diode WZ-130	
D13	Zener diode WZ-130	
D14	Zener diode WZ-140	

OTHERS

Symbol	Description	Part No.
	Heat sink	ANH-117-0
	Heat sink (small)	ANH-207-A
	Socket (transistor)	AKH-002-0
	Spacer (insulator)	AEC-043-0
	Fuse holder	AKR-013-0

12. 9 SWITCH CIRCUIT ASSEMBLY (AWS-064-0)

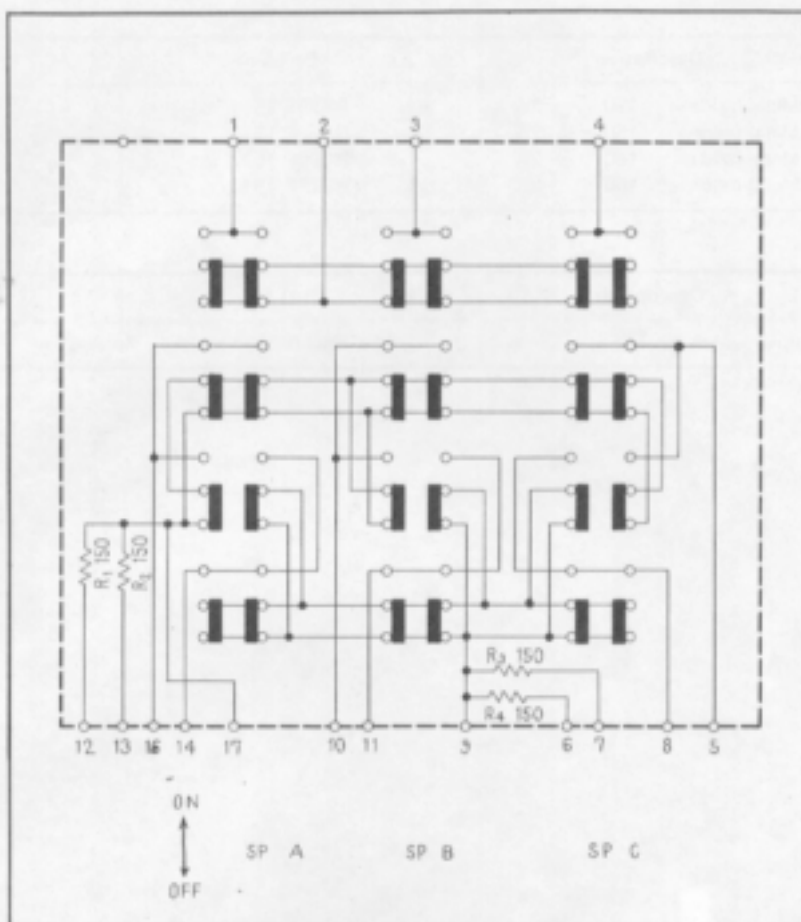

Foil Side

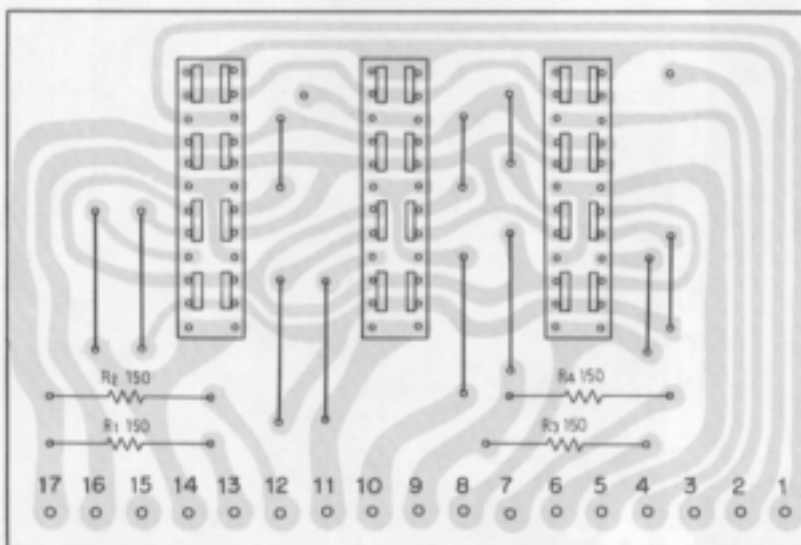

Parts List of Switch Circuit Assembly (AWS-064-0)

RESISTORS

Symbol	Description	Part No.	
R1	Metal oxide 150 2W	RS2PF 151J	
R2	Metal oxide 150 2W	RS2PF 151J	
R3	Metal oxide 150 2W	RS2PF 151J	
R4	Metal oxide 150 2W	RS2PF 151J	

SWITCH

Symbol	Description	Part No.	
	Push switch (speakers)	ASG-061-0	

12.10 SWITCH CIRCUIT ASSEMBLY (AWS-065-0)

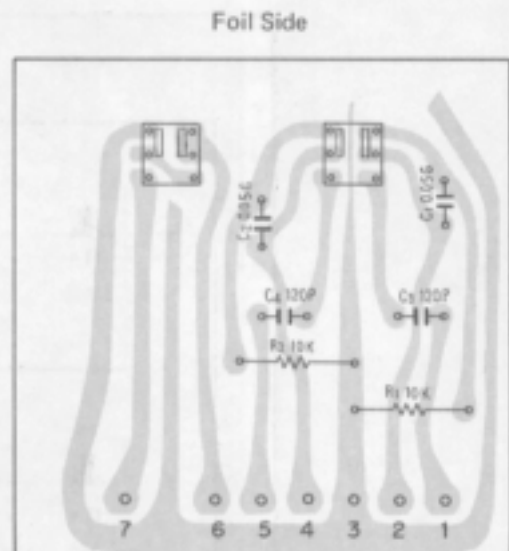
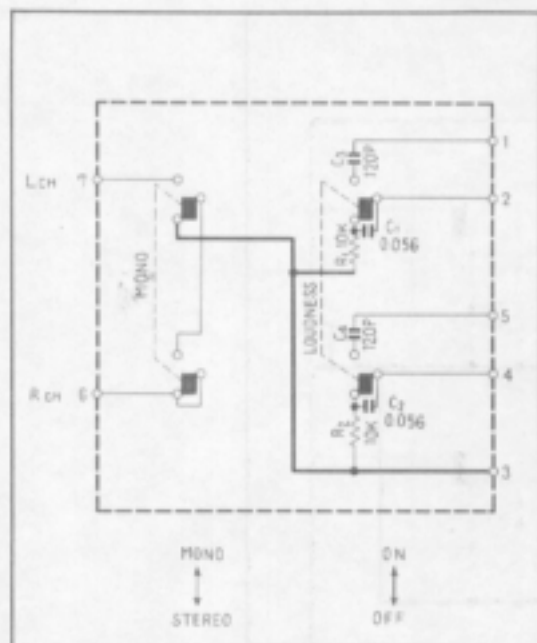

CAPACITORS

Symbol	Description	Part No.
C1	Mylar 0.056 50V	COMA 563J 50
C2	Mylar 0.056 50V	COMA 563J 50
C3	Ceramic 120p 50V	CCDSL 121K 50
C4	Ceramic 120p 50V	CCDSL 121K 50

RESISTORS

Symbol	Description	Part No.
R1	Carbon film 10k	RD&PS 103J
R2	Carbon film 10k	RD&PS 103J

SWITCH

Symbol	Description	Part No.
	Push switch (mode, loudness)	ASG-063-0

12.11 SWITCH CIRCUIT ASSEMBLY (AWS-066-0)

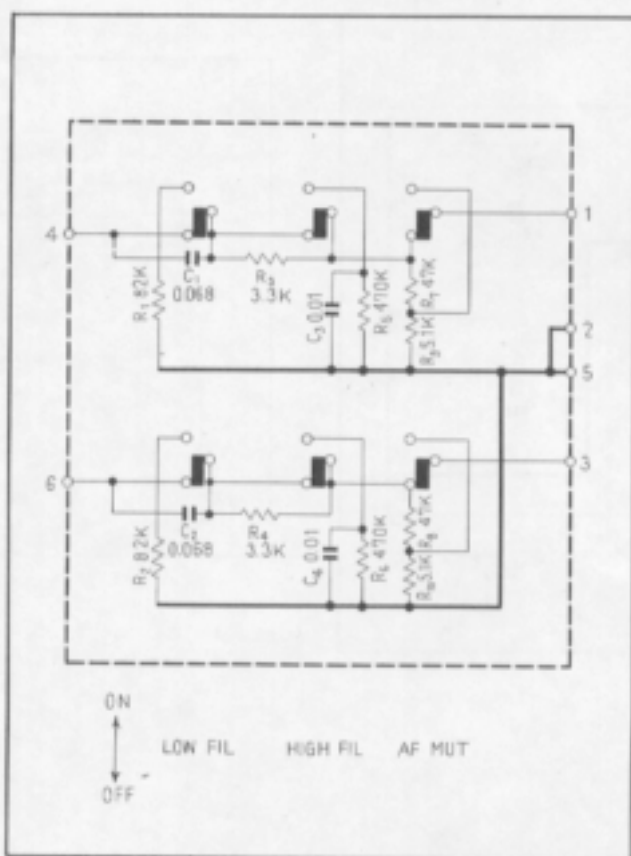

Foil Side

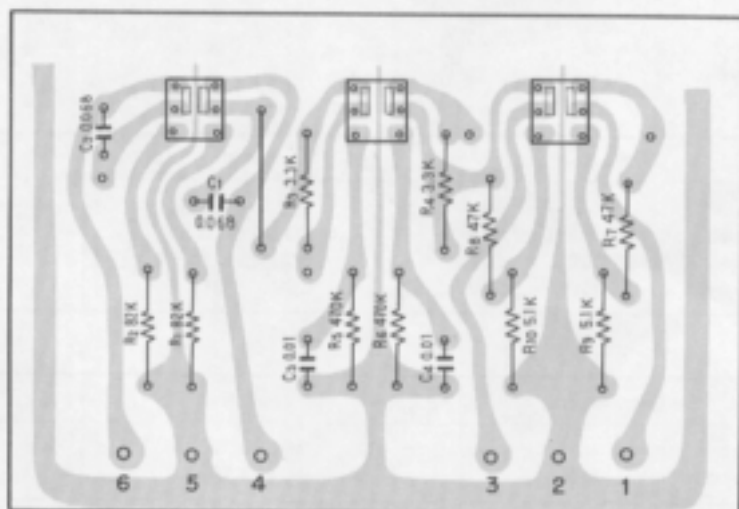

Parts List of Switch Circuit Assembly (AWS-066-0)

CAPACITORS

Symbol	Description	Part No.
C1	Mylar 0.068 50V	CQMA 683K 50
C2	Mylar 0.068 50V	CQMA 683K 50
C3	Mylar 0.01 50V	CQMA 103K 50
C4	Mylar 0.01 50V	CQMA 103K 50

RESISTORS

Symbol	Description	Part No.
R1	Carbon film 82k	RD%PM 823J
R2	Carbon film 82k	RD%PM 823J
R3	Carbon film 3.3k	RD%PM 332J
R4	Carbon film 3.3k	RD%PM 332J
R5	Carbon film 470k	RD%PM 474J
R6	Carbon film 470k	RD%PM 474J
R7	Carbon film 47k	RD%PM 473J
R8	Carbon film 47k	RD%PM 473J
R9	Carbon film 5.1k	RD%PM 512J
R10	Carbon film 5.1k	RD%PM 512J

SWITCH

Symbol	Description	Part No.
	Mini switch (filters, AF muting)	ASG-062-0

12.12 SWITCH CIRCUIT ASSEMBLY (AWS-067-0)

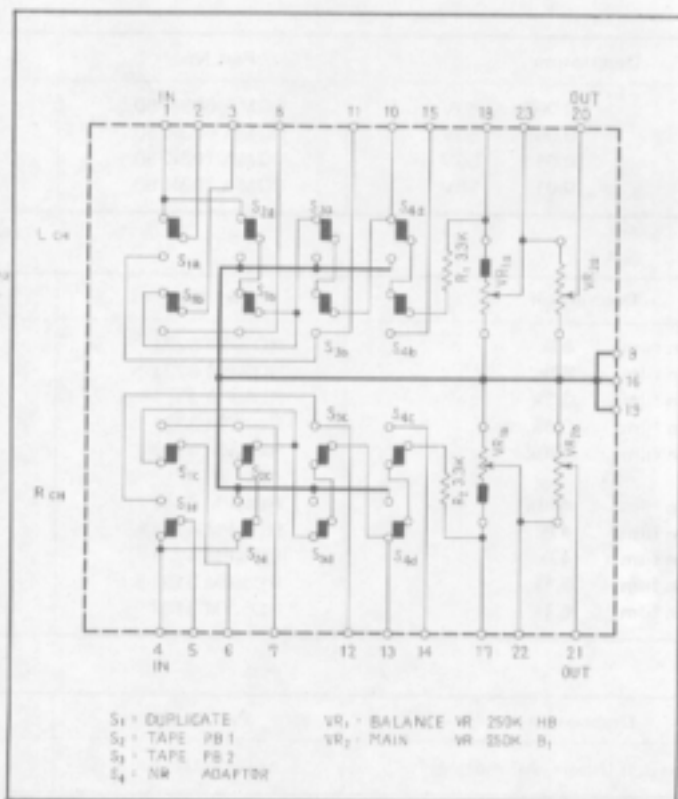

Foil Side

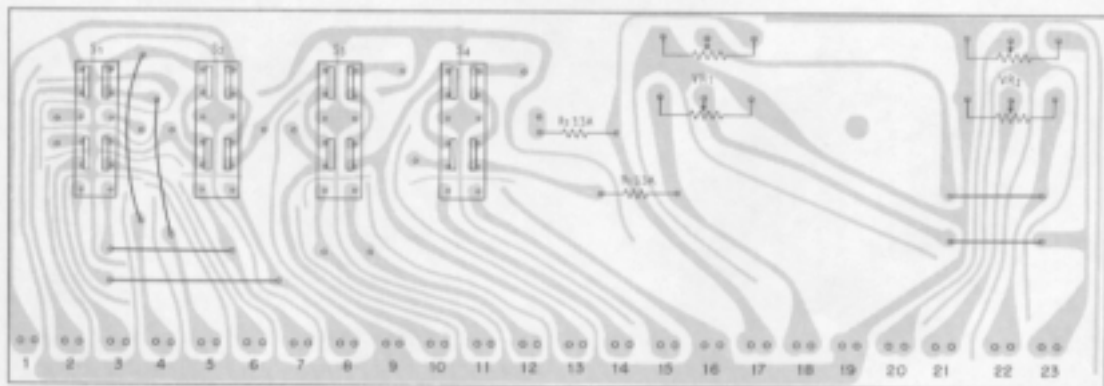

Parts List of Switch Circuit Assembly (AWS-067-0)

RESISTORS AND POTENTIOMETERS

Symbol	Description	Part No.
R1	Carbon film 3.3k	RD4PS 332J
R2	Carbon film 3.3k	RD4PS 332J
VR1	Variable resistor 250k-HB (Balance)	ACV-135-0
VR2	Variable resistor 250k-B1 (Volume)	ACV-134-0

SWITCHES

Symbol	Description	Part No.
S1	Lever switch (duplicate)	ASK-072-0
S2	Lever switch (monitor-1)	ASK-072-0
S3	Lever switch (monitor-2)	ASK-072-0
S4	Lever switch (NR adaptor)	ASK-072-0

12.13 SWITCH CIRCUIT ASSEMBLY (AWS-068-0)

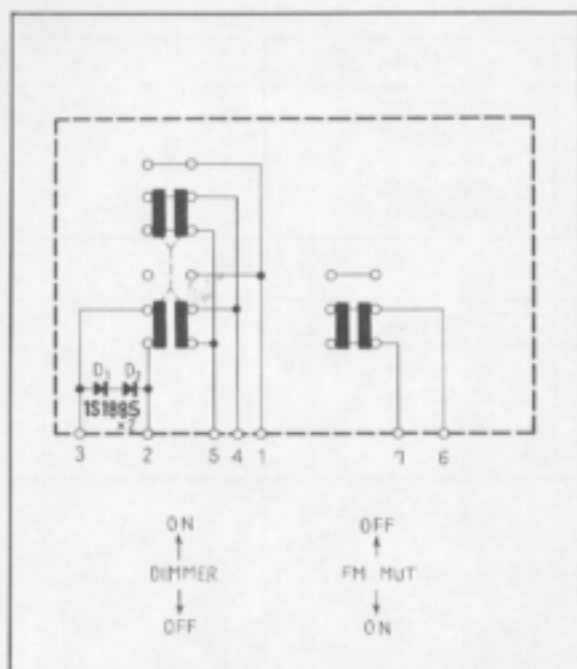

Foil Side

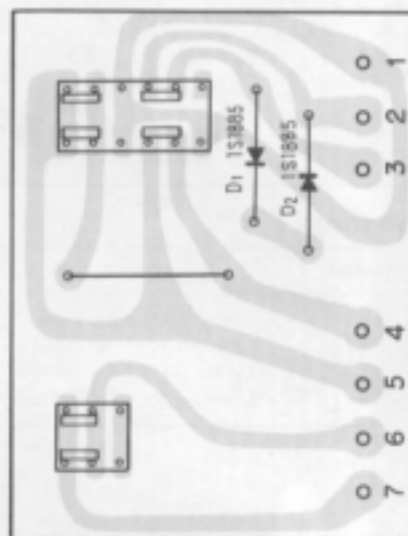

SEMICONDUCTORS

Symbol	Description	Part No.	
D1	Diode 1S1885 or S1B01-01		
D2	Diode 1S1885 or S1B01-01		

SWITCH

Symbol	Description	Part No.	
	Push switch (dimmer, FM muting)	ASG-064-0	

12.14 SWITCH CIRCUIT ASSEMBLY (AWS-069-0)

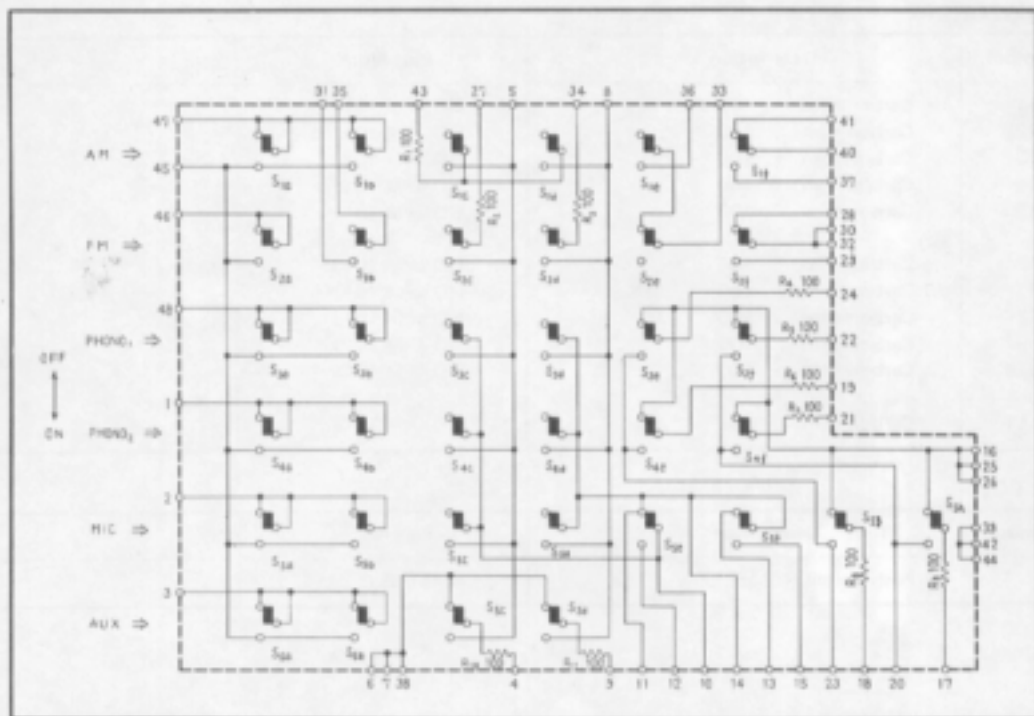

Foil Side

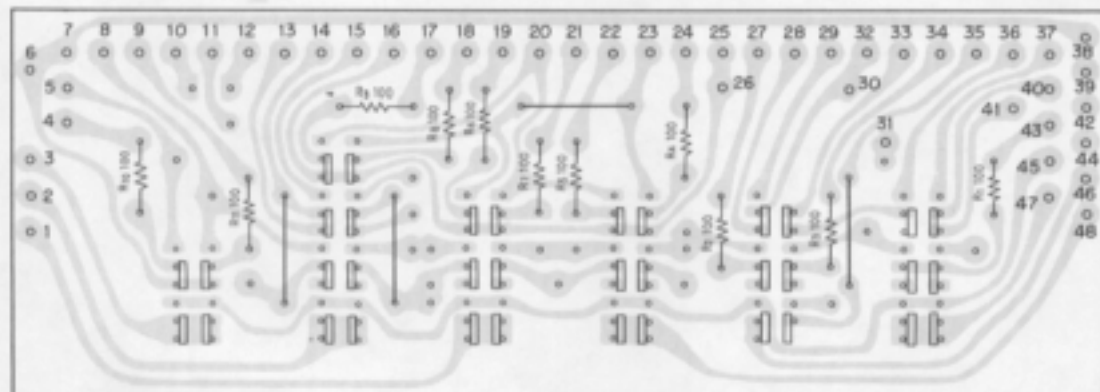

Parts List of Switch Circuit Assembly (AWS-069-0)

RESISTORS

Symbol	Description	Part No.
R1	Carbon film 100	RD%PM 101J
R2	Carbon film 100	RD%PM 101J
R3	Carbon film 100	RD%PM 101J
R4	Carbon film 100	RD%PM 101J
R5	Carbon film 100	RD%PM 101J
R6	Carbon film 100	RD%PM 101J
R7	Carbon film 100	RD%PM 101J
R8	Carbon film 100	RD%PM 101J
R9	Carbon film 100	RD%PM 101J
R10	Carbon film 100	RD%PM 101J
R11	Carbon film 100	RD%PM 101J

SWITCH

Symbol	Description	Part No.
	Push switch (function)	ASG-065-0

12.15 5P CONNECTOR ASSEMBLY (AWX-062-0)

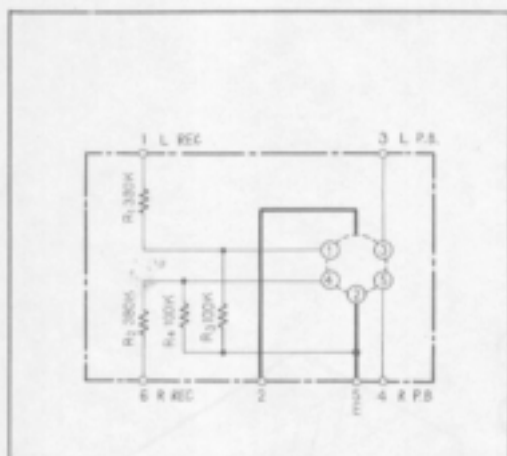

Foil Side

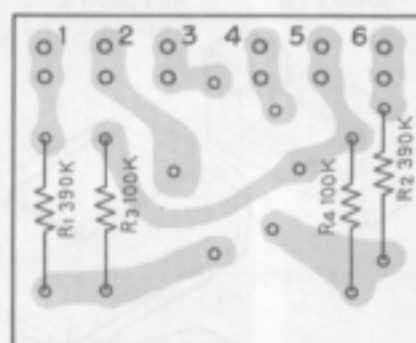

RESISTORS AND OTHER

Symbol	Description	Part No.	
R1	Carbon film 390k	RD%PS 394J	
R2	Carbon film 390k	RD%PS 394J	
R3	Carbon film 100k	RD%PS 104J	
R4	Carbon film 100k	RD%PS 104J	
	Connector (DIN type 5P)	AKP-007-0	

13. PACKING METHOD AND PART NUMBERS

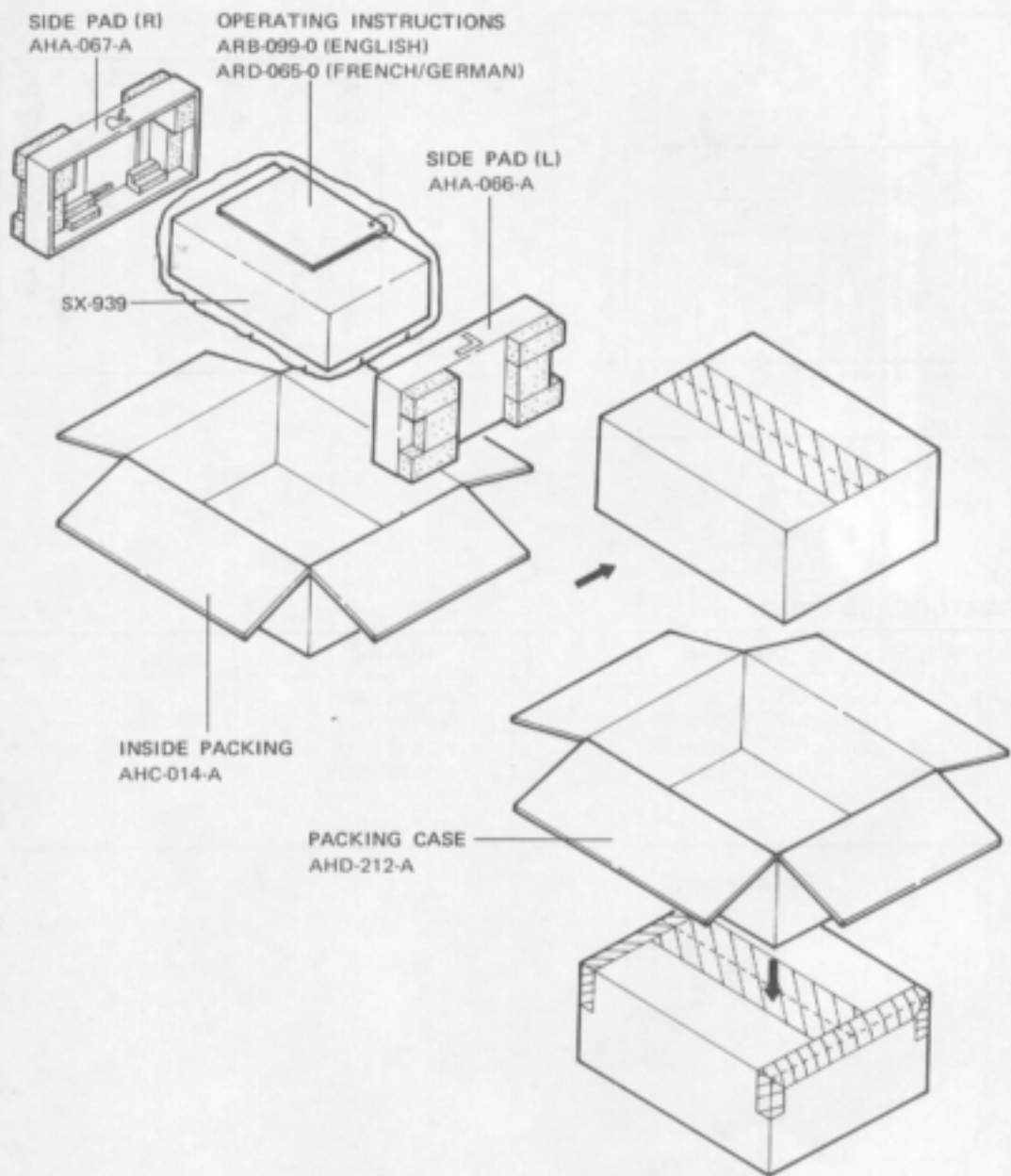

4. SCHEMATIC DIAGRAMS, P. C. BOARD PATTERN AND PARTS LIST FOR 220V ONLY MODEL

2SA745A
2SB503S
2SB541P
2SC1403A
2SD370S
2SD388P



4.1 CIRCUIT CONNECTION DIAGRAM AND MISCELLANEOUS PARTS

220V ONLY MODEL

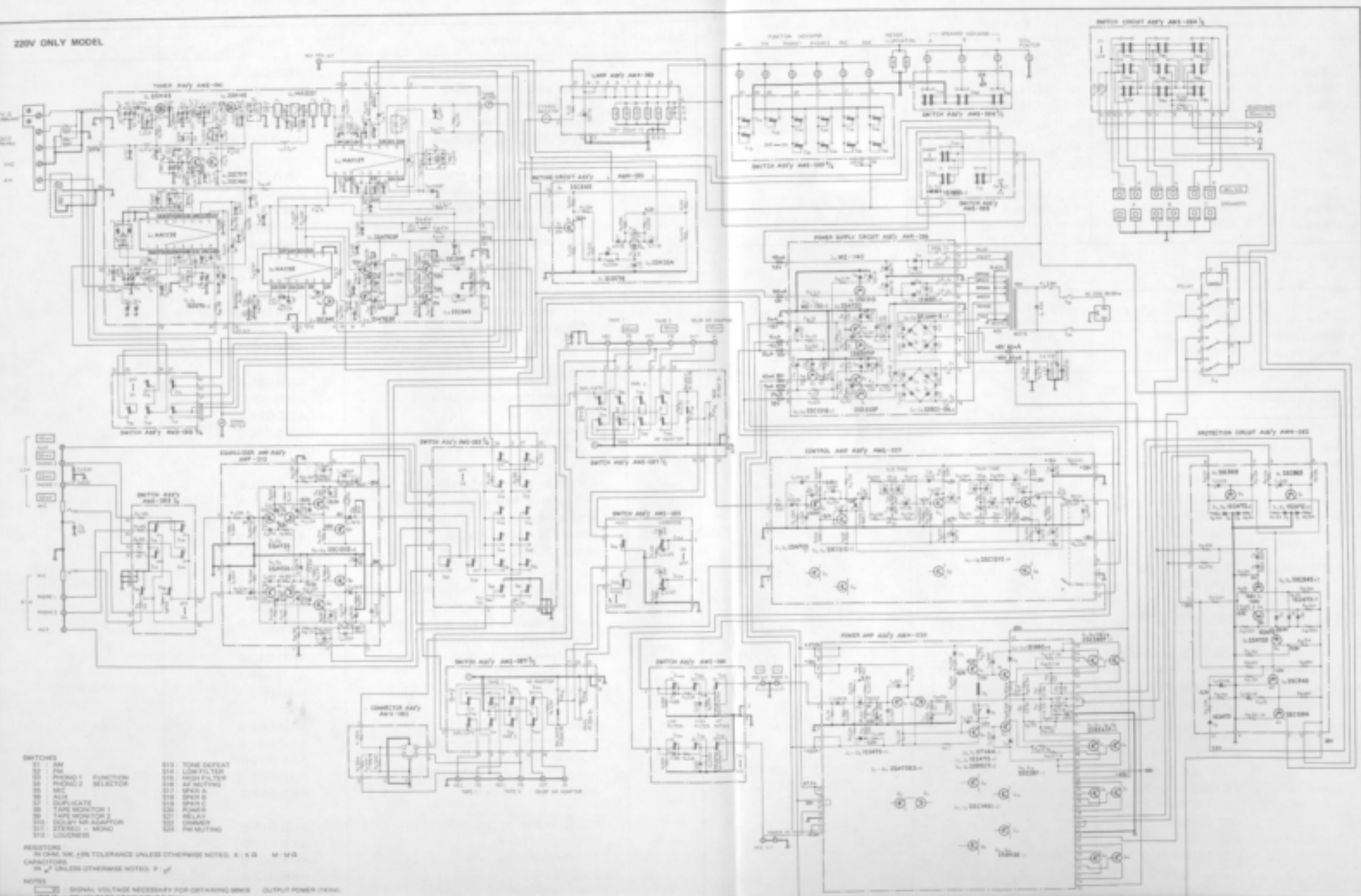

AM	MONITOR 1	FUNCTION	SELECTOR
MONITOR 1	MONITOR 2	STEREO - MONO	LOUNDS
MONITOR 2	STEREO - MONO	LOUNDS	

NOTES:
- SIGNAL VOLTAGE NECESSARY FOR OBTAINING MAX. OUTPUT POWER (REF.)
- DC VOLTAGE AT NO INPUT SIGNAL.
- DC CURRENT AT NO INPUT SIGNAL.
RESISTOR: 10 OHM, 5% TOLERANCE UNLESS OTHERWISE NOTED. K - x 10³ M - x 10⁶
CAPACITORS: IN UNLESS OTHERWISE NOTED. P - P.P.C.
P.P.C. = POLYESTER FILM

- CAPACITORS: IN μ F UNLESS OTHERWISE NOTED p: pF.
- RESISTORS: IN Ω , %W UNLESS OTHERWISE NOTED k: k Ω , M: M Ω .

Miscellaneous Parts (220V only model)

CAPACITORS

Symbol	Description	Part No.
C1	Ceramic 0.01 250V	ACG-001-0
C2	Ceramic 0.01 150V	ACG-004-0
C3	Electrolytic 10,000 50V	ACH-019-0
C4	Electrolytic 10,000 50V	ACH-019-0
C5		
C6		
C7	Ceramic 0.01 50V	CKDYF 103Z 50
C8	Ceramic 0.01 50V	CKDYF 103Z 50
C9	Ceramic 0.01 50V	CKDYF 103Z 50
C10	Ceramic 0.01 50V	CKDYF 103Z 50

RESISTORS

Symbol	Description	Part No.
R1	Metal oxide 2.7k 2W	RS2P 272J
R2	Metal oxide 2.7k 2W	RS2P 272J

SEMICONDUCTORS

Symbol	Description	Part No.
Q1	Transistor 2SD388P-L or M (2SC1403A-R, O or Y) (2SD370S-R, O or Y)	
Q2	Transistor 2SD388P-L or M (2SC1403A-R, O or Y) (2SD370S-R, O or Y)	
Q3	Transistor 2SB541P-L or M (2SA745A-R, O or Y) (2SB530S-R, O or Y)	
Q4	Transistor 2SB541P-L or M (2SA745A-R, O or Y) (2SB530S-R, O or Y)	
Q5	Transistor 2SB541P-L or M (2SA745A-R, O or Y) (2SB530S-R, O or Y)	
Q6	Transistor 2SB541P-L or M (2SA745A-R, O or Y) (2SB530S-R, O or Y)	
Q7	Transistor 2SD388P-L or M (2SC1403A-R, O or Y) (2SD370S-R, O or Y)	
Q8	Transistor 2SD388P-L or M (2SC1403A-R, O or Y) (2SD370S-R, O or Y)	

SWITCHES

Symbol	Description	Part No.
S20	Lever switch (Power)	ASK-068-0
S21	Relay	ASR-007-0

OTHERS

Symbol	Description	Part No.
	Tuner assembly	AWE-041-A
	Power amplifier assembly	AWH-030-0
	Control amplifier assembly	AWG-027-0
	Equalizer amplifier assembly	AWF-013-0
	Protection circuit assembly	AWM-062-0
	Power supply circuit assembly	AWR-056-0
	Switch circuit assembly (function)	AWS-069-0
	Switch circuit assembly (speakers)	AWS-064-0
	Switch circuit assembly (mode, loudness)	AWS-065-0
	Switch circuit assembly (filters)	AWS-066-0
	Switch circuit assembly (tape monitor)	AWS-067-0
	Switch circuit assembly (dimmer)	AWS-068-0
	Lamp board assembly	AWX-069-0
	SP connector assembly	AWX-062-0
	Muting circuit assembly	AWM-063-0
	Front panel assembly	ANB-260-B
	Wooden cabinet assembly	AMM-035-B
	Foot	AEC-027-B
	Tuning shaft assembly	AXA-056-0
	Tuning pulley assembly	AXA-015-A
	Ferrite antenna holder assembly	AXB-001-B
	Dial pointer assembly	AAF-031-A
	Dial scale	AAG-074-A
	Meter (Tuning and Signal)	AAW-029-0
	Knob (Tuning)	AAA-026-A
	Knob (Bass-main, Treble-main, Volume, Balance)	AAB-068-A
	Knob (Bass-sub, Treble-sub)	AAB-069-B
	Knob (Power, Tone, Duplicate, Monitor, 4-CH adaptor)	AAD-040-0
	Knob (Speaker A, B, C)	AAD-064-A
	Knob (Low cut, High cut, -20dB)	AAD-065-A
	Knob (Function)	AAD-066-A
	Knob (Mode, Loudness)	AAD-067-A
	Coupler (knob-to-switch)	AAE-007-0
	Knob (Dimmer, FM muting)	AAD-082-A
	Phono jack-B (6 jacks)	AKB-017-0
	Phono jack-A (4 jacks)	AKB-014-0
	Phono jack (1 jack)	AKB-019-0
	Antenna terminal board	AKA-002-0
	Binding post for ground	AKE-012-A
	Power transformer	ATT-180-A

Symbol	Description	Part No.
	Ferrite loopstick antenna	ATB-026-0
	Balun	T22-025-A
	Fuse 3.15A (protection)	AEK-042-0
	Fuse 1A (protection)	E21-031-0
	Pilot lamp 8V, 0.3A (dial scale)	E22-032-0
	Pilot lamp 8V, 0.3A (meter)	AEL-015-0
	Pilot lamp 8V, 50mA (program indicator)	AEL-022-0
	Pilot lamp 8V, 50mA (program indicator)	AEL-024-0
	Connector (AC power)	AKP-008-0
	Speaker output terminal	AKE-014-0
	Phone jack (Headphone)	K72-026-0
	Phone jack (Microphone)	K72-024-0
	Socket (power transistor)	AKH-001-0
	Jumper plug	AKM-004-A
	Pilot lamp socket	AKK-002-0
	Fuse holder (protection)	K91-008-0
	AC cord grommet	AEC-079-0
	Spacer (insulator)	AEC-076-0
	Screw M4 x 15	ABA-010-A
	Operating instructions (English)	ARB-099-0
	Operating instructions (French/German)	ARD-065-0
	FM T-type antenna	ADH-002-0
	Packing case	AHD-212-A
	Side pad (L)	AHA-066-A
	Side pad (R)	AHA-067-A
	Inside packing	AHC-014-A

14.2 POWER SUPPLY CIRCUIT ASSEMBLY (AWR-056-0)

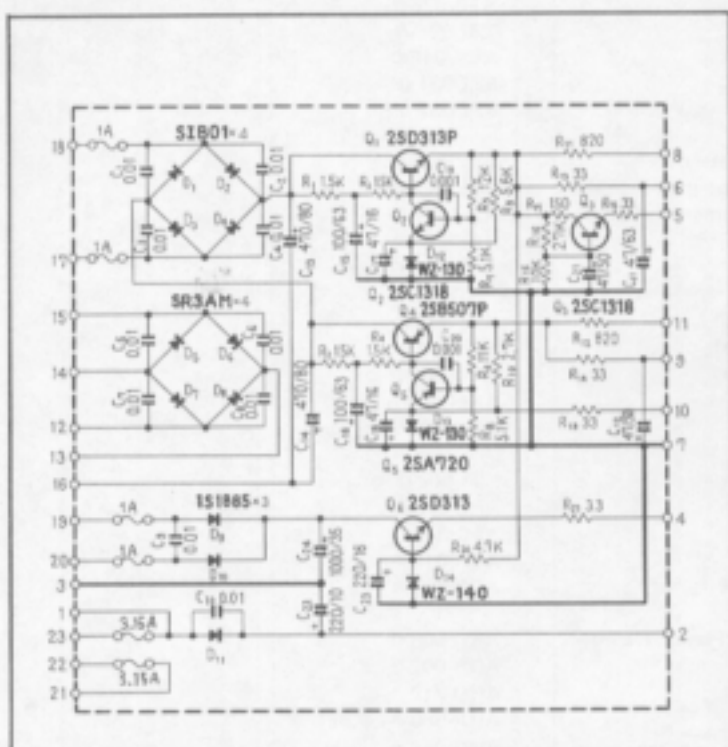

25D313
25D313P
25B507P



25A720
25C1318



Foil Side

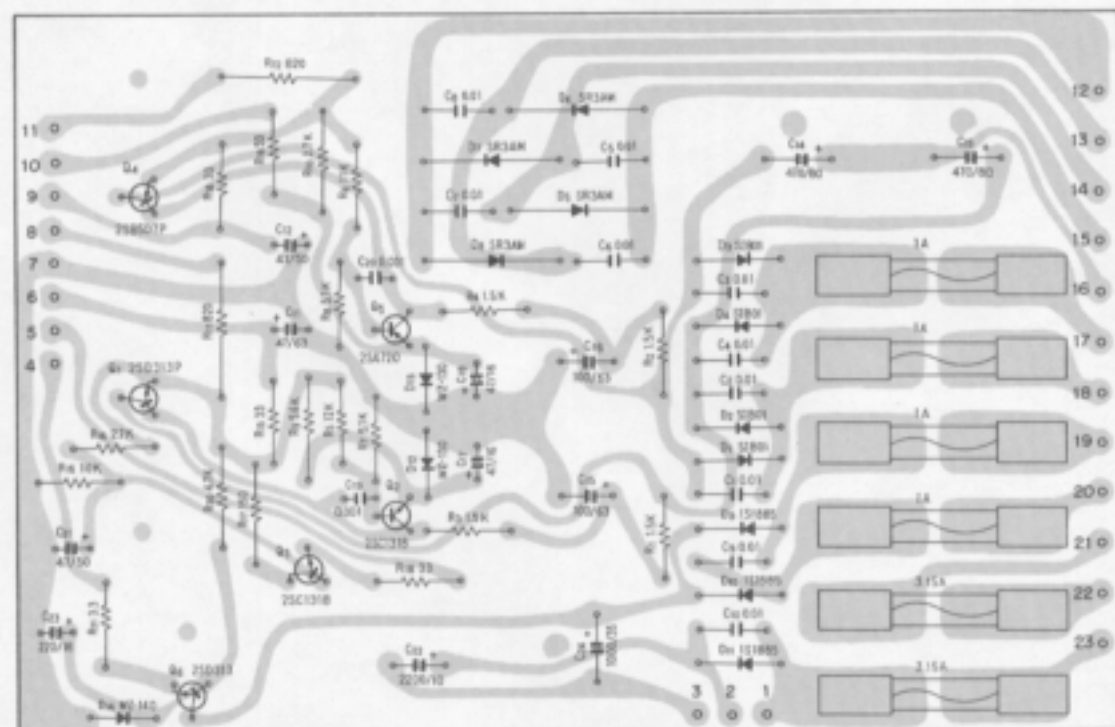

Parts List of Power Supply Circuit Assembly (AWR-056-0)

CAPACITORS

Symbol	Description			Part No.
C1	Ceramic	0.01	150V	ACG-004-0
C2	Ceramic	0.01	150V	ACG-004-0
C3	Ceramic	0.01	150V	ACG-004-0
C4	Ceramic	0.01	150V	ACG-004-0
C5	Ceramic	0.01	150V	ACG-004-0
C6	Ceramic	0.01	150V	ACG-004-0
C7	Ceramic	0.01	150V	ACG-004-0
C8	Ceramic	0.01	150V	ACG-004-0
C9	Ceramic	0.01	150V	ACG-004-0
C10	Ceramic	0.01	150V	ACG-004-0
C11	Electrolytic	47	63V	CEA 470P 63
C12	Electrolytic	47	50V	CEA 470P 50
C13	Electrolytic	470	80V	ACH-038-0
C14	Electrolytic	470	80V	ACH-038-0
C15	Electrolytic	100	63V	CEA 101P 63
C16	Electrolytic	100	63V	CEA 101P 63
C17	Electrolytic	47	16V	CEA 470P 16
C18	Electrolytic	47	16V	CEA 470P 16
C19	Ceramic	0.001	50V	CKDYF 102Z 50
C20	Ceramic	0.001	50V	CKDYF 102Z 50
C21	Electrolytic	47	50V	CEA 470P 50
C22	Electrolytic	2,200	10V	CEA 222P 10
C23	Electrolytic	220	16V	CEA 221P 16
C24	Electrolytic	1,000	35V	ACH-039-0

RESISTORS

Symbol	Description			Part No.
R1	Carbon film	1.5k		RD%PS 152J
R2	Carbon film	1.5k		RD%PS 152J
R3	Carbon film	1.5k		RD%PS 152J
R4	Carbon film	1.5k		RD%PS 152J
R5	Carbon film	12k		RD%PS 123J
R6	Carbon film	11k		RD%PS 113J
R7	Carbon film	5.1k		RD%PS 512J
R8	Carbon film	5.1k		RD%PS 512J
R9	Carbon film	5.6k	½W	RD%PS 562J
R10	Metal oxide	2.7k	1W	RS1P 272J
R11	Metal oxide	820	2W	RS2P 821J
R12	Metal oxide	820	2W	RS2P 821J
R13	Carbon film	33		RD%PS 330J
R14	Carbon film	33		RD%PS 330J
R15	Carbon film	10k		RD%PS 103J
R16	Carbon film	2.7k		RD%PS 272J
R17	Carbon film	150	½W	RD%PS 151J
R18	Carbon film	33		RD%PS 330J
R19	Carbon film	33		RD%PS 330J
R20	Carbon film	4.7k	½W	RD%PS 472J
R21	Carbon film	3.3		RD%PS 3R3J

REC-213
SEMICONDUCTORS

Symbol	Description	Part No.
Q1	Transistor 2SD313P-E or D	
Q2	Transistor 2SC1318-Q or R	
Q3	Transistor 2SC1318-Q or R	
Q4	Transistor 2SB507P-E or D	
Q5	Transistor 2SA720-Q or R	
Q6	Transistor 2SD313-E or D	
D1	Diode SIB01-04	
D2	Diode SIB01-04	
D3	Diode SIB01-04	
D4	Diode SIB01-04	
D5	Diode SR3AM-8	
D6	Diode SR3AM-8	
D7	Diode SR3AM-8	
D8	Diode SR3AM-8	
D9	Diode 1S1885 (SIB01-01)	
D10	Diode 1S1885 (SIB01-01)	
D11	Diode 1S1885 (SIB01-01)	
D12	Zener diode WZ-130	
D13	Zener diode WZ-130	
D14	Zener diode WZ-140	

OTHERS

Symbol	Description	Part No.
	Heat sink	ANH-117-0
	Heat sink (small)	ANH-207-A
	Socket (transistor)	AKH-002-0
	Spacer (insulator)	AEC-043-0
	Fuse holder	AKR-010-0

10.2 ABGLEICHVERFAHREN (GERMANY)

ABGLEICHEN DES FM-TEILS

1. Regeleinstellungen am SX-939

Die Steuerelemente (Knöpfe und Schalter) des SX-939 sind wie folgt einzustellen:

POWER (Stromzuführung): ON (Ein)
 FUNCTION (Funktion): FM
 FM MUTING (FM-Dämpfung): OFF (Aus)

2. Schaltungen zwischen Prüfsatz und dem SX-939

- Der Ausgang von einem FM-Prüfsender ist mit den 300-Ohm-Antennenanschlüssen des SX-939 zu verbinden.
- Ein Klirrfaktormeßgerät ist mit den Anschlußbuchsen des SX-939 TAPE REC (Band-aufnahme) zu verbinden.
- Ein Millivolt-Wechselspannungsmesser ist parallel zum Klirrfaktormeßgerät mit den Anschlußbuchsen TAPE REC (Band-aufnahme) des SX-939 zu verbinden.

3. Der FM-Prüfsender und der SX-939 sind beide auf eine Anzeige von 98 MHz einzustellen.

4. Der Ausgangspegel des FM-Prüfsenders ist auf minimale Einstellung herunterzudrehen.

5. Der untere Kern ist zu drehen und so einzustellen, daß die Nadel des Abstimm-Meters zentriert ist.

6. Der Ausgang des FM-Prüfsenders ist, moduliert bei 400 Hz bei einer Abweichung von ± 75 kHz, auf 60 dB zu erhöhen.

7. Der obere Kern ist zu drehen und so einzustellen, daß die Verzerrung minimal wird. Obige Schritte 4 - 7 sollen mehrmals nacheinander wiederholt werden, bis keine merkliche Verbesserung erzielt wird.

8. Der Ausgangspegel des FM-Prüfsenders ist, moduliert bei 400 Hz bei einer Frequenzabweichung von ± 75 kHz, auf 10 dB einzustellen.

9. Es ist auf maximalen Ausgang bei 87,4 MHz einzustellen.

10. Es ist auf maximalen Ausgang bei 106 MHz einzustellen.

11. Es ist auf maximalen Ausgang bei 90 MHz einzustellen.

12. Es ist auf maximalen Ausgang bei 106 MHz einzustellen.

Obige Schritte 11 - 12 sind mehrfach nacheinander zu wiederholen, bis keine weitere merkliche Verbesserung erzielt wird.

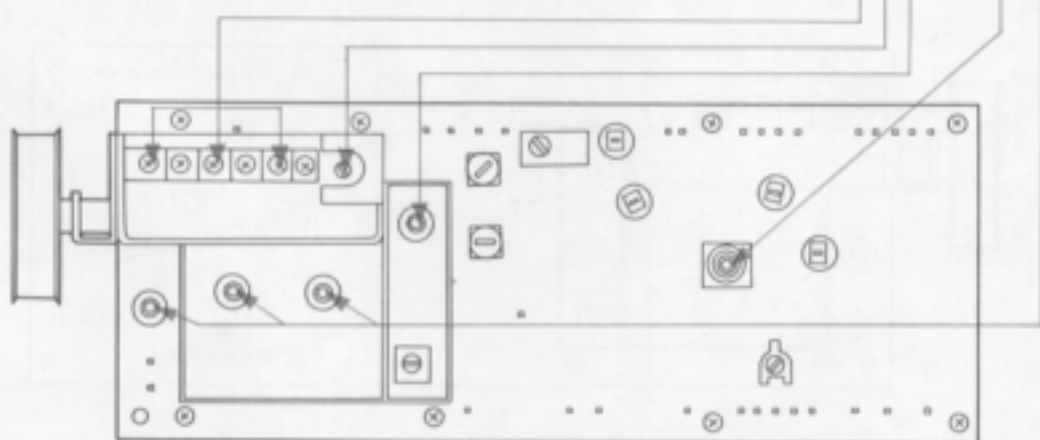

ABGLEICHEN DES FM-MPX-TEILS

Zur Beachtung:

Die folgenden Einstellschritte sollten nicht vor Beendigung des Abgleichs des FM-Teils (siehe oben 1 - 12) durchgeführt werden. Der Multiplex-Prüfsender ist mit den Außenmodulatoranschlüssen des FM-Prüfsenders zu verbinden.

1. Regeleinstellungen am SX-939

Die Steuerelemente (Knöpfe und Schalter) des SX-939 sind wie folgt einzustellen:

POWER (Stromzuführung):	ON (Ein)
FUNCTION (Funktion):	FM (UKW)
FM MUTING (FM-Dämpfung):	OFF (Aus)

2. Schaltungen zwischen Prüfsatz und dem SX-939

- Der Ausgang vom FM-Prüfsender ist mit den 300- Ω -Antennenanschlüssen des SX-939 zu verbinden.
- Der Ausgang vom MPX-Prüfsender ist an die Außenmodulatoranschlüsse des FM-Prüfsenders anzuschließen.
- Die x-Anoden des Oszilloskops sind mit den Anschlüssen PILOT OUT am MPX-Prüfsender und die y-Anoden mit dem Anschluß 18 zu verbinden.
- Der Millivolt-Wechselspannungsmesser ist mit den TAPE REC (Band-aufnahme)-Anschlüssen (mit Umschaltmöglichkeit von den Kanälen LH auf RH) zu verbinden.

3. Modulation des Multiplex-Prüfsenders

L + R (1 kHz): Abweichung von 67,5 kHz

PILOT (19 kHz): Abweichung von 7,5 kHz

4. Der Ausgang des FM-Prüfsenders ist auf minimales Niveau einzustellen.
5. Am Oszilloskop ist eine Einstellung auf eine stehende Wellenform der Lissajousschen Figur durchzuführen.
6. Der FM-Prüfsender ist auf einen Pegelausgang von 60 dB zurückzustellen und entweder der LH- oder der RH-Kanal zu modulieren.
7. Es ist auf maximale Trennung einzustellen.

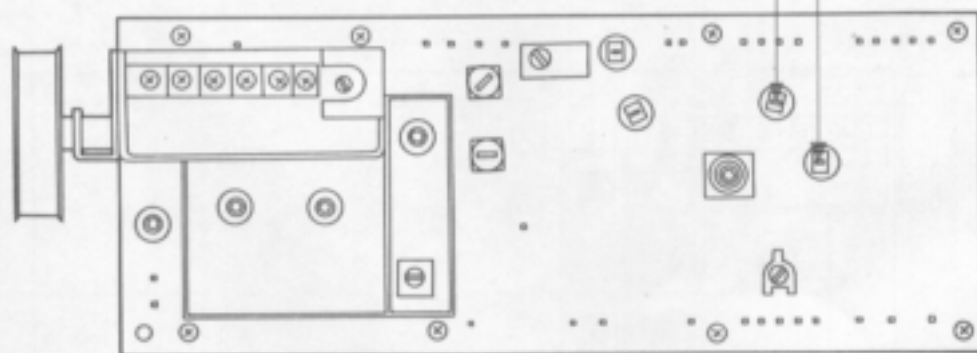

ABGLEICHEN DES AM-TEILS

1. Regeleinstellungen am SX-939
Die Steuerelemente (Knöpfe und Schalter) des SX-939 sind wie folgt einzustellen:
POWER (Stromzuführung): ON (Ein)
FUNCTION (Funktion): AM
2. Schaltungen zwischen Prüfsatz und dem SX-939
 - Der AM-Prüfsender ist mit den AM-Antennenanschlüssen (in Reihenschaltung mit einem künstlichen Widerstand von $1\text{ k}\Omega$) zu verbinden.
 - Der Millivolt-Wechselspannungsmesser ist mit den Anschlußbuchsen TAPE REC (Band-aufnahme) zu verbinden.
3. Der AM-Prüfsender ist auf eine Modulation von 30 % bei 400 Hz einzustellen.
4. Der Ausgang des AM-Prüfsenders ist auf 30 dB bei 600 kHz einzustellen. Es ist der maximale Ausgang bei gleichzeitiger Einstellung des Ferritstabantennenkerns einzustellen.
5. Es ist der maximale Ausgang bei einer Frequenzeinstellung auf 1400 kHz einzustellen. Obige Einstellungen 4 - 5 sind mehrfach zu wiederholen, bis keine weitere merkliche Verbesserung erzielt wird.
6. Der AM-Prüfsender ist direkt mit den Anschlüssen AM ANT (Antenne) zu verbinden.
7. Bei einer Frequenz von 1400 kHz und einem Ausgang des AM-Prüfsenders von 36 dB ist auf einen Niederfrequenzausgang von 70mV einzustellen.
8. Bei einem Ausgang des AM-Prüfsenders von 80 dB ist eine Einstellung auf einen Niederfrequenzausgang von 310mV durchzuführen.

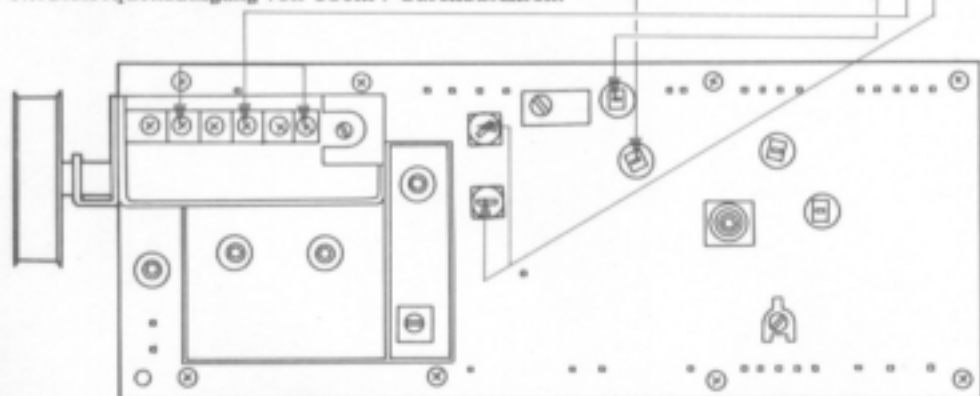

ABGLEICHEN DER ENDVERSTÄRKERSTUFE

1. Es ist nichts an die Eingangsbuchsen des SX-939 anzuschließen; ein künstlicher Widerstand von $8\ \Omega$ ist über die Lautsprecheranschlüsse anzulegen.
2. Ein Millivolt-Gleichspannungsmesser ist zwischen Anschluß 10 (25) und Erde zu schalten.
3. Eine Einstellung soll so erfolgen, daß die Spannung auf Null gebracht wird.
4. Der Gleichspannungsmesser ist zwischen die Anschlüsse 50 (38) und 44 (32) zu schalten.
5. Eine Einstellung soll so erfolgen, daß die Spannung auf 50 mV gebracht wird.

